



ERD2

Addressable System



Operating Manual

CONTENTS

ERD2 System Characteristics	01
1. LED Description and Keypad Reference	02
2. LCD Reference	05
2-1. Access Level	06
2-2. LCD Display	08
2-3. LEVEL1 LCD Selection Menu Instruction	09
(1) Alarm Data	09
(2) Wire Break Data	10
(3) Fault Data	11
(4) History Log	12
(5) System Review	13
2-4. LEVEL2 LCD Selection Menu Instruction	14
(1) Loop Test	14
(2) Loop Review	16
(3) Loop Setting	17
(4) Setting	18
2-5. LEVEL3 LCD Selection Menu Instruction	20
(1) Time Setting	20
(2) History Log CLR	20
(3) Download File	21
(4) Output Delay	22
(5) Brightness	22
(6) Security Code	23
3. System Wiring Instruction	25
4. Installation and Testing Notes	25
5. Wiring Diagram	26
5-1. Detector Wiring	27
5-2. Area Bell Wiring	30
5-3. Manual Call Point Wiring	31
6. Annunciator Wiring	32
7. Trouable Shooting	37
8. The SOP for Troubleshooting the Cluster Network	38
9. The Step to Remove Network Trouble	39



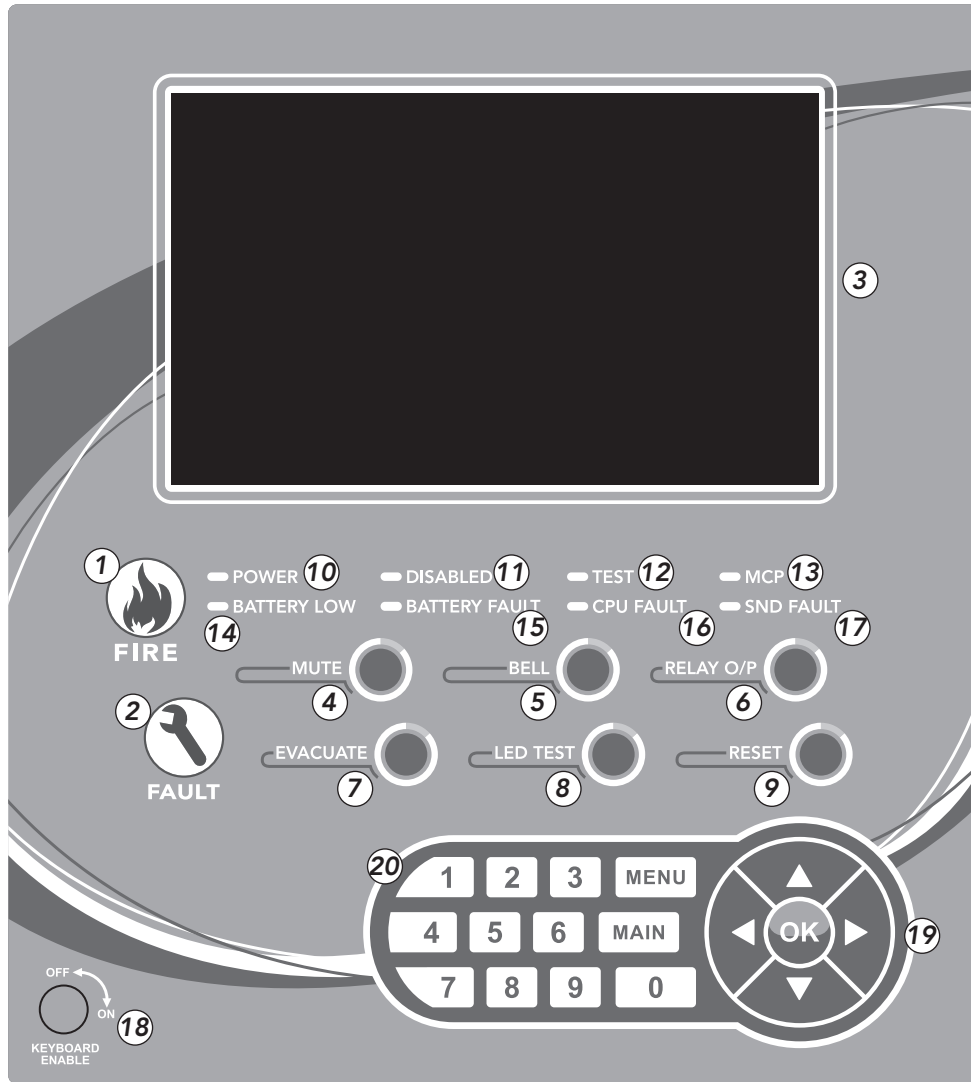

ERD2 System Characteristics

- Each loop can connect up to 250 addressable devices, maximum two loops and total 500 addressable points from single control panel.
- Optional panel with networking feature, the maximum networking configuration is 32 loops and total addressable points up to 8000.
- Large LCD screen (50 x 15 lines) allows more events to be displayed on the same screen.
- Addresses displayed on the LCD shows 24 letters including spaces.
- Loop device can be set up to be temporarily isolated.
- Events log can be stored up to 20480 pieces.
- Data can be downloaded/uploaded via USB access.
- Individual loop module in the test feature can save time under test.
- On-board self-test feature for simulating alarm output.
- The programming information will not disappear due to AC power fault or standby power fault.
- The loop card can detect if the external wiring is short circuited or overloaded. When an error is detected, the loop card will isolate the loop system and protect it from external wiring burning out.
- The system provides a security code to guarantee the external settings and protect it from incorrect setting change caused by improper operation.
- The wall-mounted control panel is reduced to be able to equipped easily.

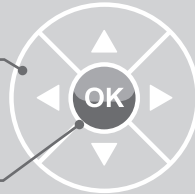
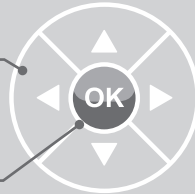

Number	Indicators	Descriptions	LED Status	
			Normal	Abnormal
1	FIRE LED	Indicates that the panel is receiving a fire alarm signal or is being tested. If a new fire alarm signal is received when operating this control panel, the operation will be interrupted and the fire alarm control panel will respond to the signal.	————	Blinking
2	FAULT LED	Indicates an active system in the trouble condition which could include missing end-of-line resistor, loop problem, wirebreak, broken fuse, module fault, AC/DC fault or repeated addressable point number. The buzzer will sound when FAULT LED goes on. Repeated addressable point number will also be indicated on the LCD.	————	ON
3	LCD	Large LCD screen (50 x 15 lines) allows more events to be displayed on the same screen.	————	————
4	MUTE SWITCH	A buzzer on the panel beeps during alarm, wirebreak and other abnormal conditions. a. Temporary Mute : Press MUTE switch once to stop a buzzer temporarily. The LED will light. The buzzer will become active again if the panel detects any alarm, wirebreak and other abnormal conditions. Press MUTE switch again to turn off the LED.	————	————

Number	Indicators	Descriptions	LED Status	
			Normal	Abnormal
4	MUTE SWITCH	<p>b. Fault Status : When it is in the trouble condition, the panel buzzer beeps once every 6 seconds.</p> <p>c. Wirebreak Status : When it is in the wirebreak condition, the panel buzzer beeps once every 2 seconds.</p> <p>d. Alarm : When it is active, the panel buzzer beeps continuously.</p>	_____	_____
5	BELL SWITCH	Press BELL switch to mute bells which are connected to the panel. The LED will light. Press BELL switch again to remove mute. The LED will go off.	_____	_____
6	RELAY O/P SWITCH	NO	_____	_____
7	EVACUATE SWITCH	Press this switch, and the system can generate an alarm and activate all warning devices.	_____	_____
8	LED TEST SWITCH	Start the test mode, all the indicating LED will light up, recovery switch, all the inactive indicating LED turn off and back to previous LED status.	_____	_____
9	RESET SWITCH	Press RESET switch to reset the panel from an alarm, wirebreak and any other abnormal conditions. The LED is on while resetting and it goes off when the panel finishes resetting. It takes 10 seconds to reset the panel and the panel will be back to normal condition after checking loops for any abnormal conditions.	_____	_____
10	POWER LED	A green light indicates the Fire Alarm Control Panel is in normal condition.	ON	_____
11	DISABLED LED	A yellow light indicates a zone has been disabled.	_____	ON
12	TEST LED	Indicates that any of alarm, wirebreak or disable condition under test.	_____	ON
13	MCP LED	Indicates a manual call point has activated immediately.	_____	ON
14	BATTERY LOW LED	When the voltage is abnormal and under 22.8V, the light will go on.	_____	ON
15	BATTERY FAULT LED	Uninstall the battery will display the fault message.	_____	ON
16	CPU Fault LED	A yellow light indicates the CPU is not normal.	_____	ON
17	SND Fault LED	A yellow light indicates the SND is not normal.	_____	ON
18	KEYBOARD ENABLE SWITCH	When the switch is turned on, it means that the keyboard is able to be opened.	_____	_____

Number	Indicators	LED Descriptions	Normal	Abnormal
19	ARROW KEY, ENTER KEY	<p>a. UP, DOWN, LEFT and RIGHT </p> <p>b. ENTER Key (ENT) </p>	_____	_____
20	NUMBER KEYPAD, MENU KEY, AND MAIN KEY	<p>a. Number Keypad (0~9) </p> <p>b. MENU Key (F) </p> <p>c. MAIN Key (ESC) </p>	_____	_____

2. LCD Reference

LCD screen has a protection function. If the keyboard has unused for more than 20 seconds, the LCD light goes off. Press any key to turn on the LCD light again. If the panel detects an alarm, fault or other abnormal signals, the LCD light will illuminate and display the details.

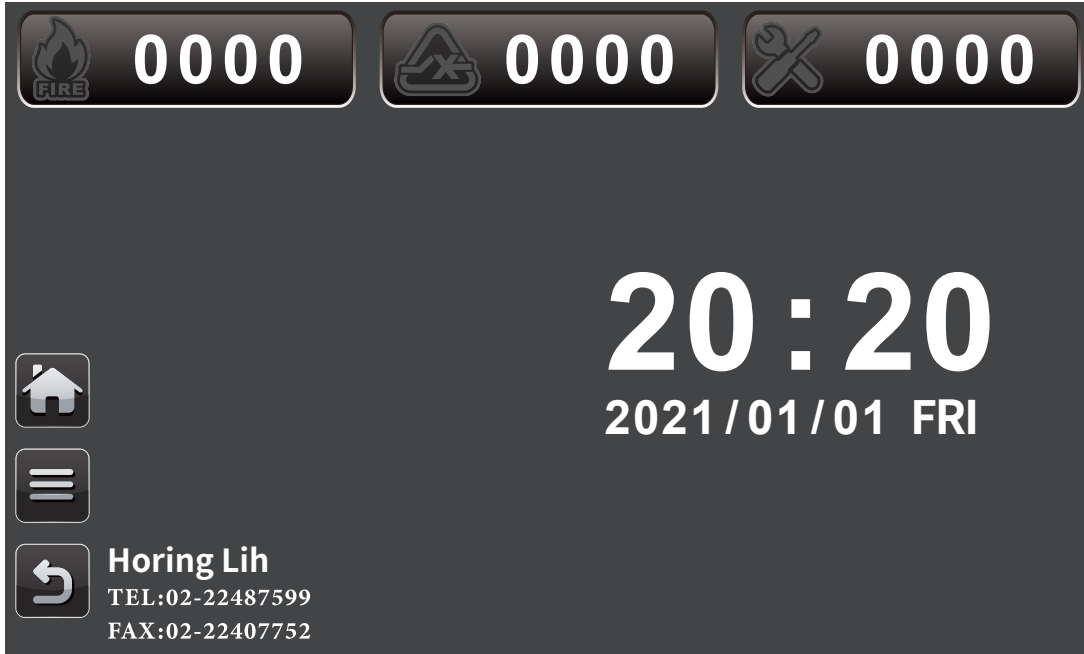

► 【Picture 1: The initial screen】

2-1 Access Level

LEVEL 1

1. In Access Level 1, only MENU, MAIN, UP, DOWN and OK controls are active.
2. In Access Level 1, user can review Alarm Data, Wire Break Data, Fault Data, History Log and System Review on LCD.

(User can select the following applications by using the touch screen or keypad.)



【Figure 2: Selection Menu screen】

※ Notice: If no item is selected, the screen will return to the initial screen after 30 seconds.

LEVEL 2

1. To enter Access Level 2, the authorized user has to use a key turning the Keyswitch to the ON position.
2. In Access Level 2, the MUTE, BELL, RELAY O/P, EVACUATE, RESET, LEFT and RIGHT controls are active.
3. In Access level 2, user can operate by Loop Test, Loop Review, Loop Setting, System Review and Setting by using the touch screen on LCD.

(User can select the following applications by using the touch screen or keypad.)



【Figure 3: Selection Menu screen】

※ Notice: If no item is selected, the screen will return to the Home screen after 30 seconds.

LEVEL3

1. To enter Access Level 3, the authorized user has to enter an access code in Set Up.
2. In Access level 3, user can operate Time Setting, History Log CLR., Download File, Output Delay, Language and Set Up by using the touch on LCD.

(User can select the following applications by using the touch screen or keypad.)



【 Figure 4: Selection Menu screen 】

※ Notice: If no item is selected, the screen will return to the initial screen after 30 seconds.

LEVEL4

1. To enter Access Level 4, an authorized key is required to open the panel cabinet door.
2. In Access Level 4, the authorized user can modify the PCB software settings, DIP switch settings and JUMP settings.

2-2 LCD Display

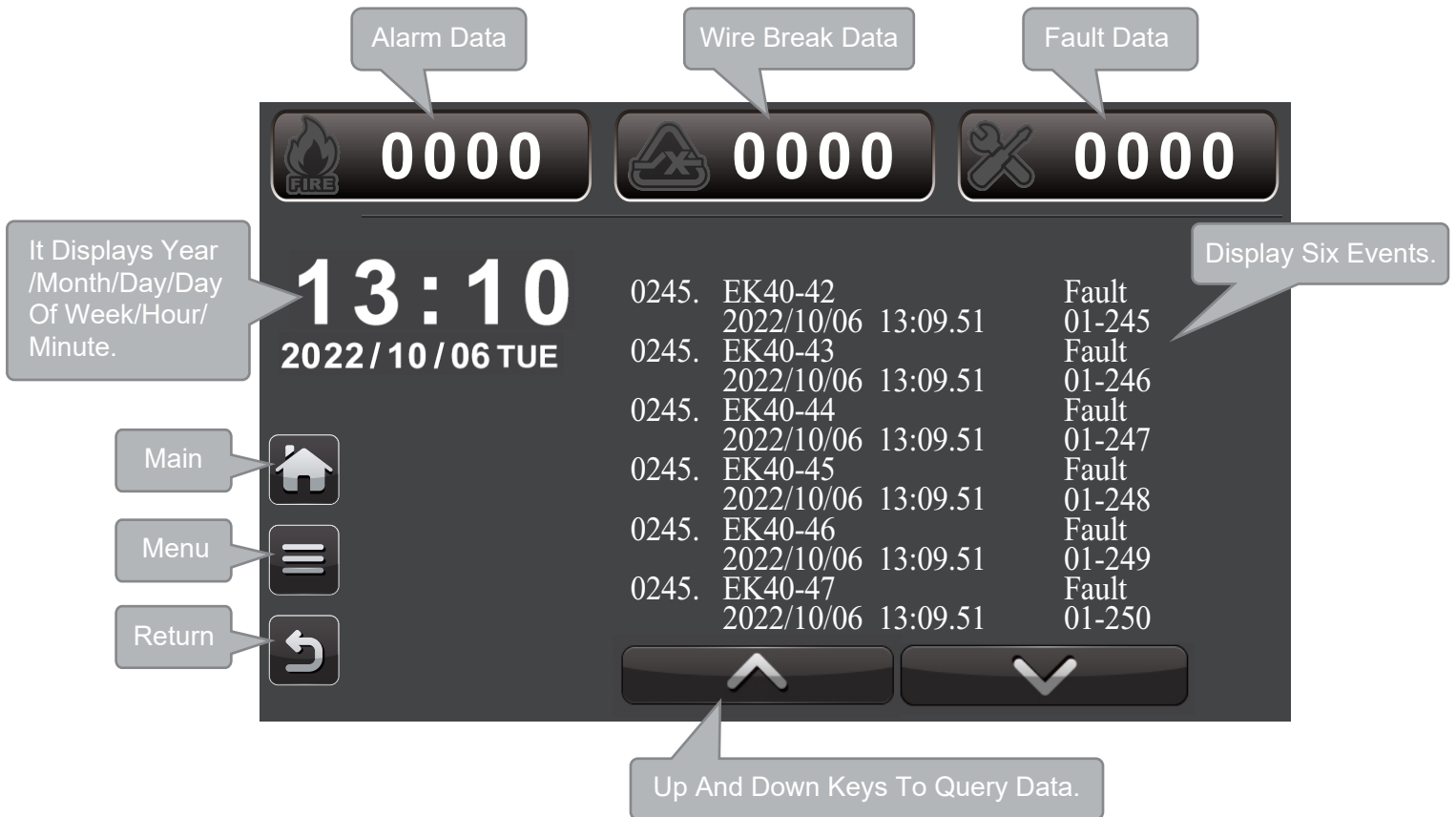

1. User can perform query and operate controls by using the touch screen or keypad. (Note 1)
2. The LCD screen can display six events, each event has an area name, status, activity time, type of module or detector (loop number and point number). If there is a "T" in the event status, for example [Alarm-T], it indicates a simulation test status.
3. When there are multiple events happened, the Alarm status event will be priority displayed on the screen than Wire Break or Fault status. User can query Wire Break Data and Fault Data to review their events.
4. When there are multiple Alarm events happened, the last Alarm event will be on the top and red lettering.

(Note 1: Alarm Data's, Wire Break Data's and Fault Data's event query can only review by touch screen.)

2-3 LEVEL1 LCD Selection Menu Instruction

(1) Alarm Data

- a. Review Alarm event through touch screen. Touch  on LCD or press MAIN to return to Main page.



【 Figure 1: No fire Alarm event on LCD screen 】

- b. Only six event displayed on LCD screen. Touch or press Up and Down keys to review all the Alarm events.

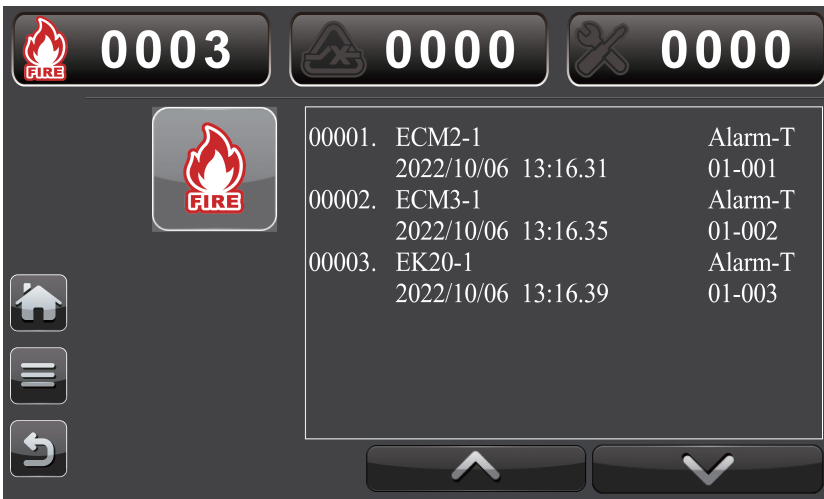

【 Figure 2: The fire Alarm events shown on LCD screen 】

(2) Wire Break Data

- a. Review Wire Break event through touch screen. Touch  on LCD screen or press MAIN to return to Main page.



【 Figure 1: No Wire Break event shown on LCD screen. 】

- b. Only six event displayed on LCD screen. Touch or press Up and Down keys to review all the Wire Break events.

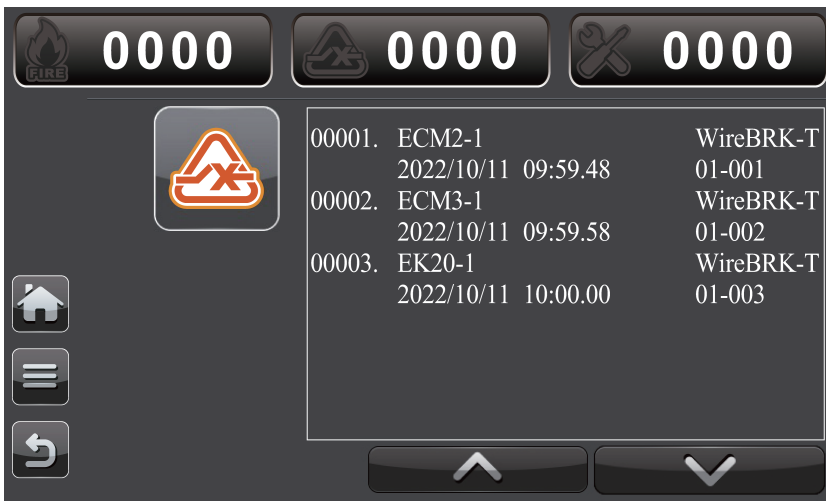

【 Figure 2: The Wire Break events shown on LCD screen. 】

(3) Fault Data

- a. Review Fault event through touch screen. Touch  on LCD screen or press MAIN to return to Main page.





【Figure 1: No Fault event shown on LCD screen.】

- b. Only six event displayed on LCD screen. Touch or press Up and Down keys to review all the Fault events.



【Figure 2: The Fault events shown on LCD screen.】

(4) History Log

- a. Enter History Log through Menu  on touch screen or press arrow keys to choose the item and press  to enter the screen below. Touch  or press to return to Main page.





※ History Log can save 20480 events.



【Figure 1: The screen shows activity events in History Log.】

- b. Check method I: Use Up and Down keys on touch screen to review every 6 History Log events per page. Long pressing on Up or Down key for quick review.
 Check method II: Press Up and Down arrow keys on front keypad to review every 6 History Log events per page. No quick review function.

(5) System Review



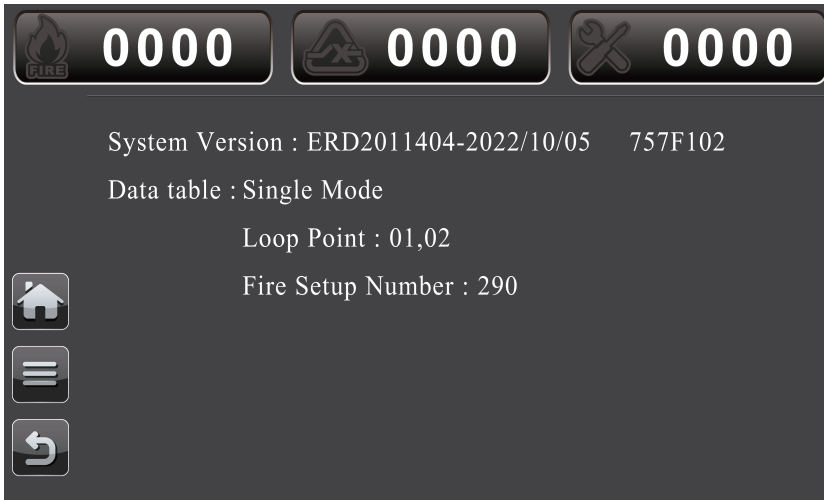

- a. Enter System Review through Menu  on touch screen or press arrow keys to choose the item and press  to enter the screen below. Touch  or press  to return to Main page.
- b. Here you may check System Version, Loop Point (the enabled loops), and Fire Setup Number (number of addressable points) as below.

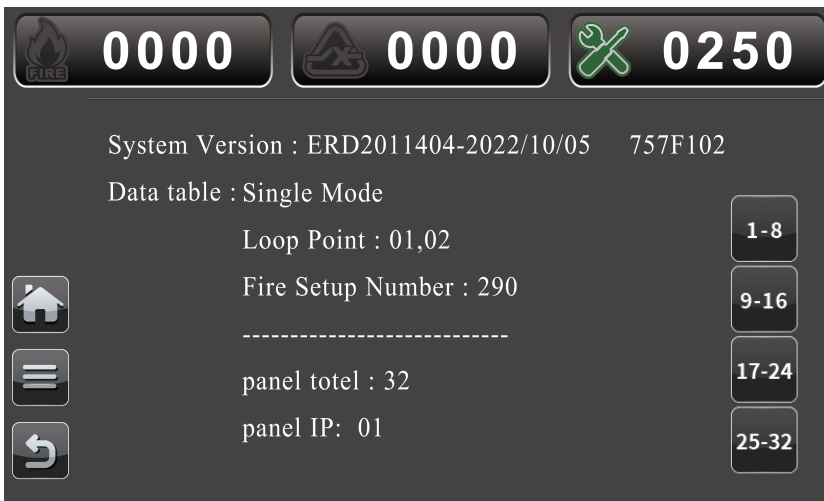

- c. In Multiple Mode, you may check the networking status, for example the panel total (total number of networking panels, 02~32) and the Panel IP (01~32).



【Figure 1: Multiple Mode】



d. In Multiple Mode, press     item, you may check the networking status, green indicator of the loop: ONLINE, red indicator of the loop: OFFLINE.



【Figure 2 : Check networking status in Multiple Mode.】

2-4 LEVEL2 LCD Selection Menu Instruction

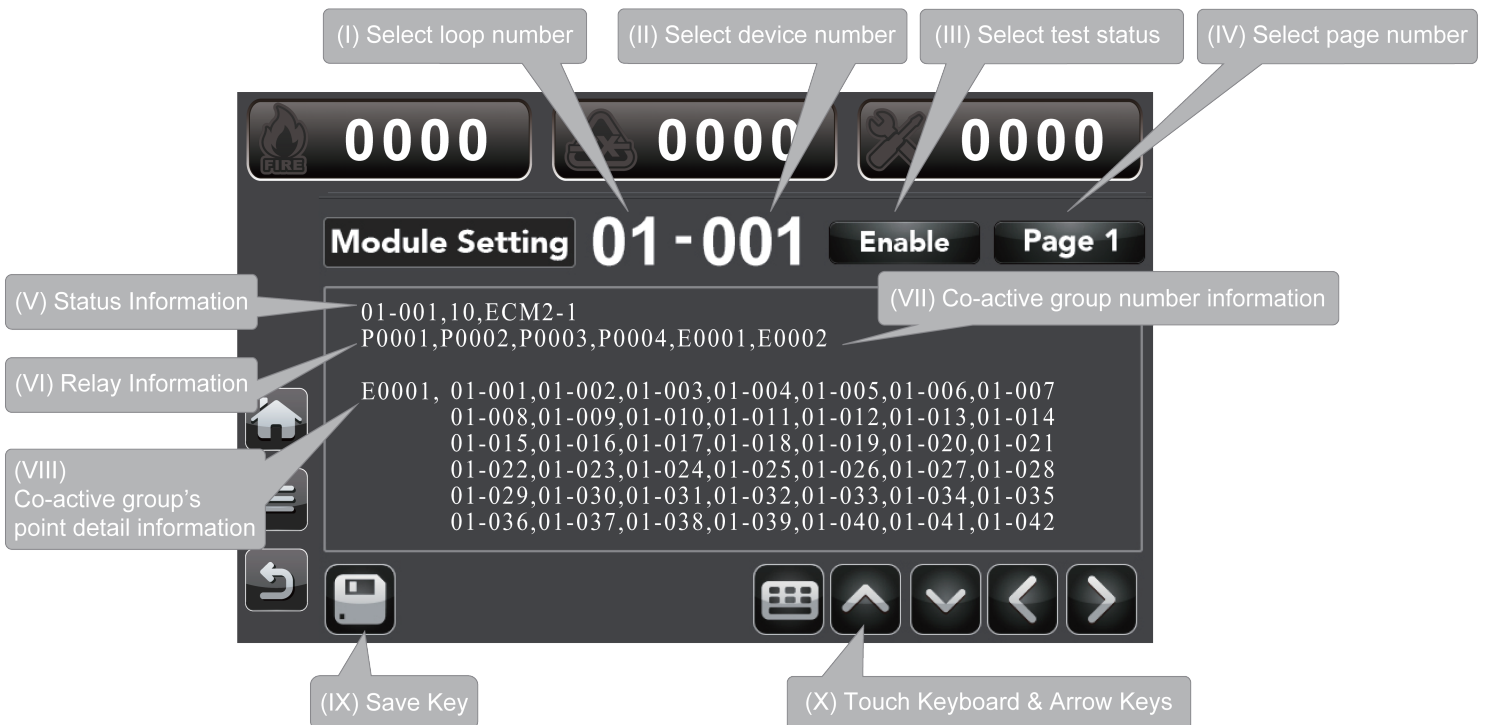

(1) Loop Test

a. Enter Loop Test through Menu  on touch screen or press arrow keys to choose the item and press  to enter the screen below. Touch  or press MAIN to return to Main page.





b. Touch Screen Keyboard Description



(1) Select Loop Number:

- Use touch screen keyboard , choose the loop number (01~32) .
- Use physical arrow keys , press UP, DOWN, LEFT and RIGHT to choose the loop number (01~32) .

(2) Select Device Number:

- Use touch screen keyboard , choose the device number (001~250) .
- Use physical arrow keys , press UP, DOWN, LEFT and RIGHT to choose the device number (001~250) .

(3) Select Test Status:

- Use touch screen and click the test status, choose Enable, Disable, WireBreak or Alarm and press save key  to test.
- Use physical arrow keys to choose test status, use UP, DOWN, LEFT and RIGHT keys  to choose Enable, Disable, WireBreak or Alarm status and then press OK key  to test.

(4) Select Page Number:

- Use touch screen and click to choose the page number(Page 1~Page 4).
- Use physical arrow keys , press UP and DOWN keys to choose the page number (Page 1~Page 4).

※ You may also check the device's details, status, relay or co-active information.

(5) Status Information: It displays the device's addressable number, type and location name.

(6) Relay Information: It displays the relay output point (P0001~P0004).



(7) Co-active group number Information: It displays the co-active group number, total 2 sets of co-active groups and each one can activate 60 other points.

(8) Co-active group points detail information: It displays the co-active points.

(9) Save Key: On the touch screen, press it to execute the output.

(10) Touch screen Keyboard & Arrow Keys: On the touch screen, press them to query and edit numbers.

(2) Loop Review

- a. Enter Loop Review through Menu  on touch screen or press arrow keys to choose the item and press  to enter the screen below. Touch  or press MAIN to return to Main page.

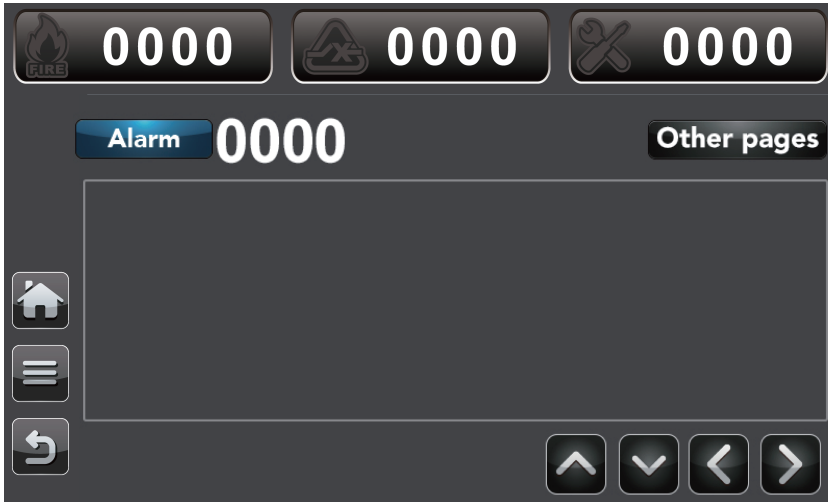

【 Figure 1: Review Alarm events 】

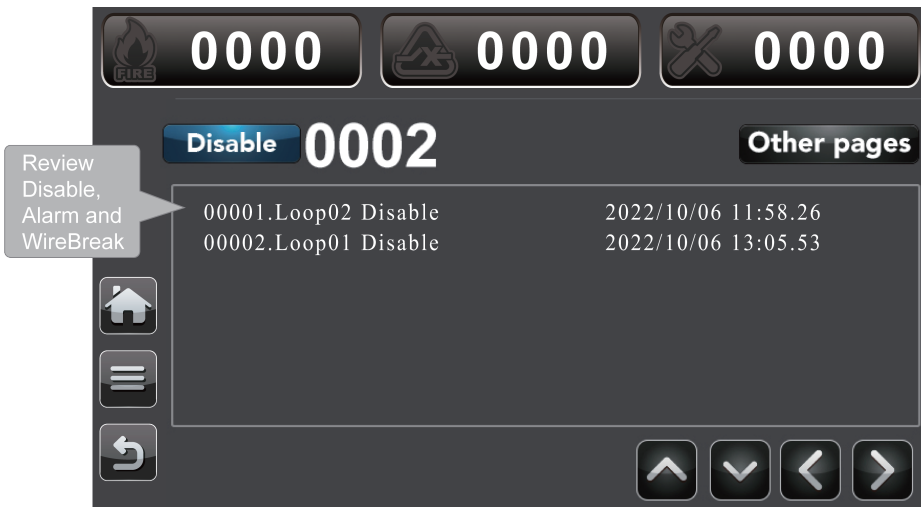

【 Figure 2: Display 7 events on each page 】









- b. Figure 1: Use touch screen to select the status, or use physical arrow keys  to choose the status.

Figure 2: More than 7 events, use touch screen or physical arrow keys  to move to next page to review all the events by UP and DOWN keys.

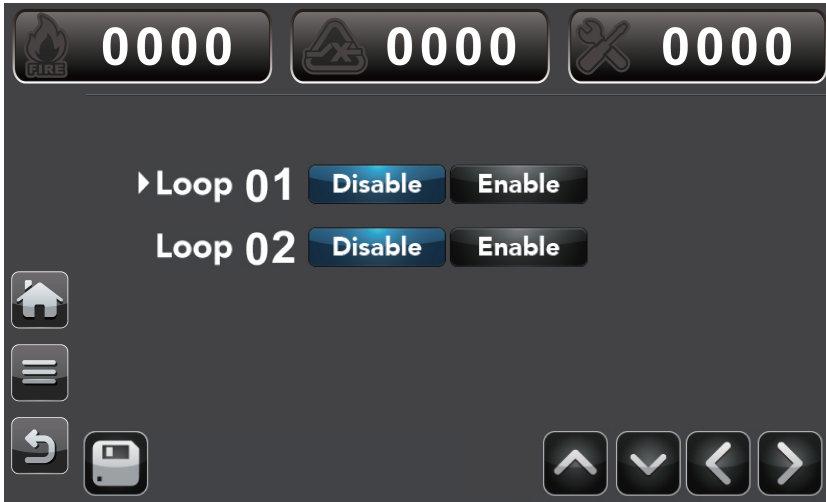

(3) Loop Setting

- a. Enter Loop Setting through Menu  on touch screen or press arrow keys to choose the item and press  to enter the screen below. Touch  or press MAIN to return to Main page.



- c. Use touch screen to click Disable or Enable of the loop, and then press Save key  to activate. Use physical arrow keys  to select the Loop, Disable or Enable , and then press OK key  to perform the Disable or Enable for the loop.

(4) Setting

- a. Enter Setting through Menu  on touch screen or press arrow keys to choose the item and press  to enter the screen below. Touch  or press MAIN to return to Main page.



【Figure 1: Screen is ready for Access Code input】

- b. Before you can enter the selection list screen, you need to input the access code: “0000” via touch screen or the physical keyboard.

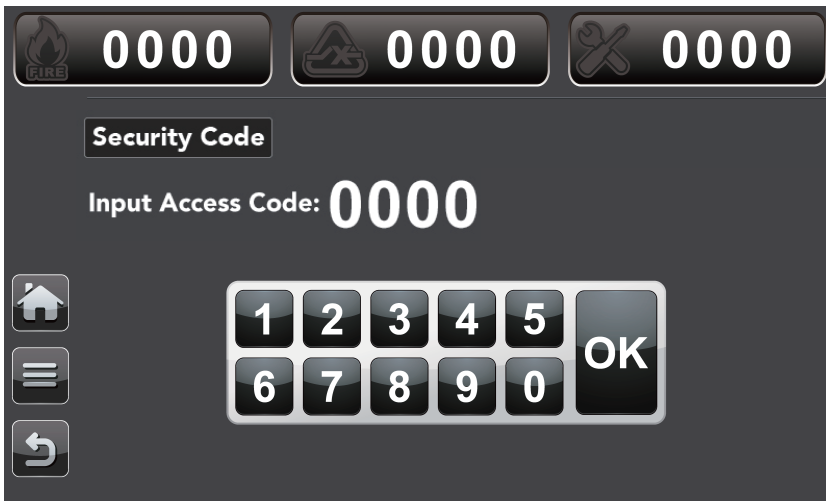

【Figure 2: Enter the access code.】

c. The screen will show "ERROR!" if the code is wrong. If the access code is correct, you will be granted into LEVEL 3.

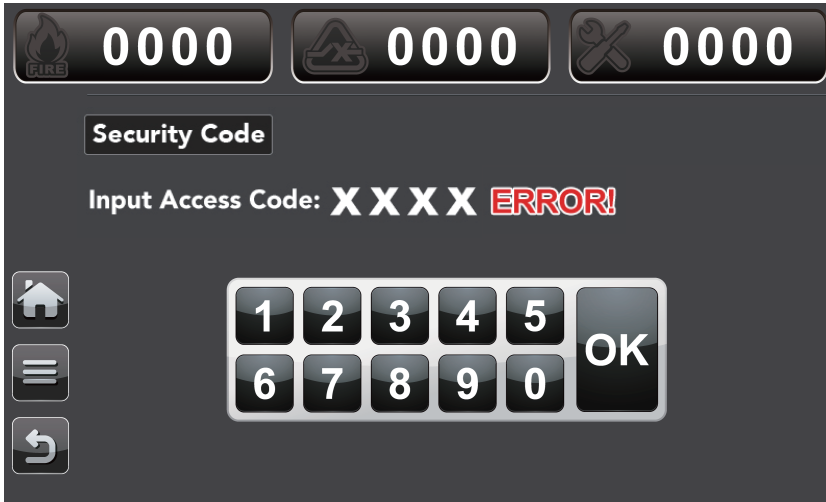

【Figure 3: ERROR! The access code is wrong.】

d. When access code is incorrect, please input the access code again and press OK to re-write.

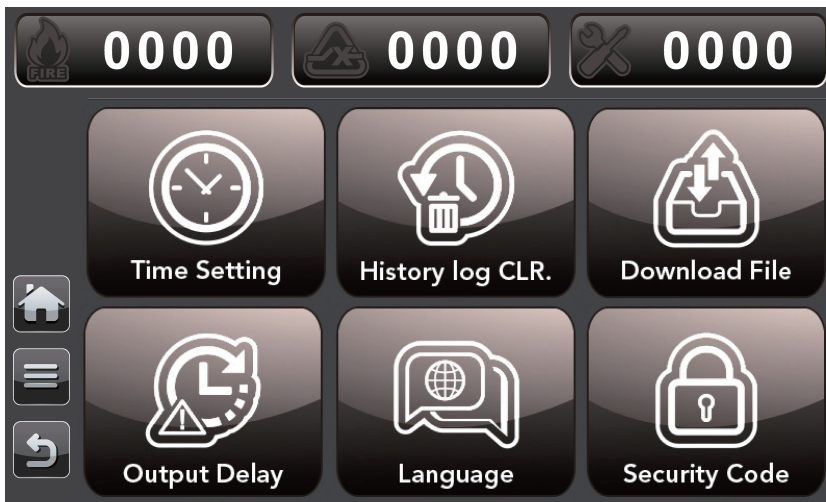

【Figure 4: LEVEL 3 screen】

e. If the access code is correct, you will be granted into LEVEL 3.

2-5 LEVEL3 LCD Selection Menu Instruction

(1) Time Setting

- a. Enter Time Setting on touch screen or press arrow keys to choose the item and press **OK** to enter the screen below. Touch **☰** or press **MAIN** to return to Main page.



- b. Use touch screen to move the cursor left and right, press UP and DOWN keys to change the time and date, and then press OK to save. You can also use physical arrow keys **⬅️➡️** to move the cursor left and right to the number you want to change, use UP and DOWN keys for setting and then press OK key **OK** to complete.

(2) History Log CLR

- a. Enter History Log CLR. on touch screen or press arrow keys to choose the item and press **OK** to enter the screen below. Touch **☰** or press **MAIN** to return to Main page.

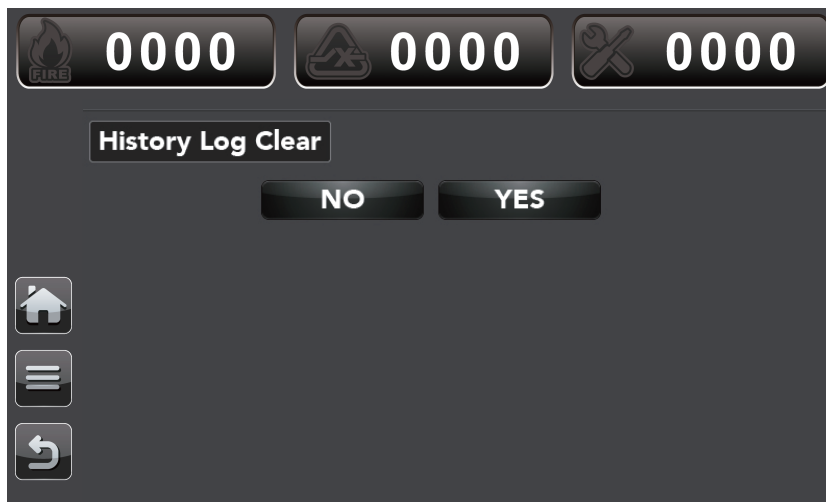

- b. Enter the screen above, use touch screen to choose NO or YES to clear history log. Press YES and click again to clear all history log. You can also use physical arrow keys **⬅️➡️** to move left and right to YES and press OK to clear all history log.

(3) Download File

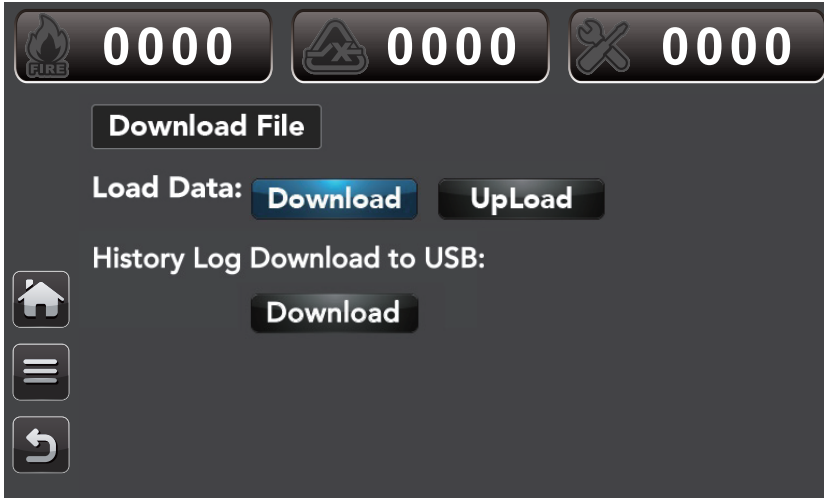

- a. Enter Download File on touch screen or press arrow keys to choose the item and press  to enter the screen below. Touch  or press  to return to Main page.





- b. Use touch screen to choose Download or Upload Load Data via Wired or Wireless, click the selection again to activate it. You can also use physical arrow keys  to move left/right/up/down and then press OK to perform the Download, Upload and History Log Download to USB.

※ Before download the history log, please open the cabinet and insert USB on 2.0 port firstly, and then process Download on touch screen. If no USB inserted, it will show "ERROR!"

(4) Output Delay

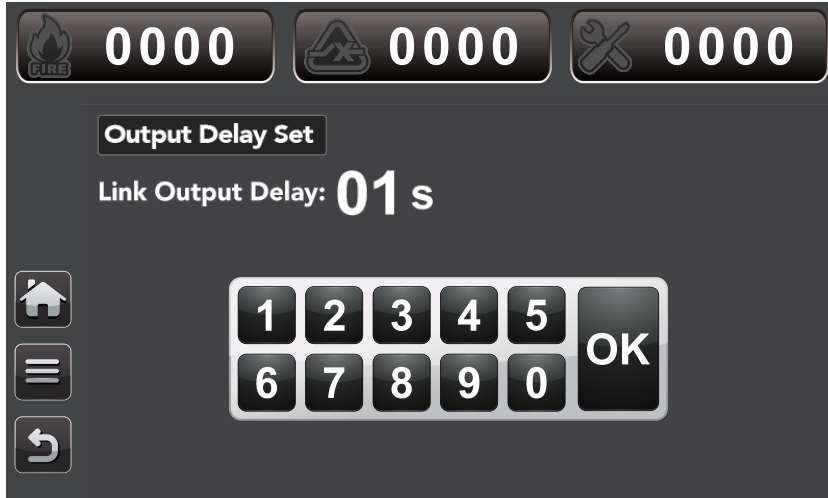
- a. Enter Output Delay on touch screen or press arrow keys to choose the item and press  to enter the screen below. Touch  or press  to return to Main page.





- b. This screen sets the length of the time the control panel delays before activating external modules, such as area bells. Use touch screen  to choose the number of seconds and then press OK to change the delay time(01~99 seconds). You can also use physical numeric keypad to set delay time and press OK key  to complete it.

(5) Language



- a. Enter Language on touch screen or press arrow keys to choose the item and press  to enter the screen below. Touch  or press  to return to Main page.



- b. Enter the screen above, chose language in ENGLISH or TRADITIONAL CHINESE on touch screen, click once to change the language immediately. You can also select language via physical arrow keys  to move left and right to select and then press OK key  to change.

※ Note: The programming data cannot be converted languages through this function.

(6) Security Code

- a. Enter Security Code on touch screen or press arrow keys to choose the item and press  to enter the screen below. Touch  or press  to return to Main page.

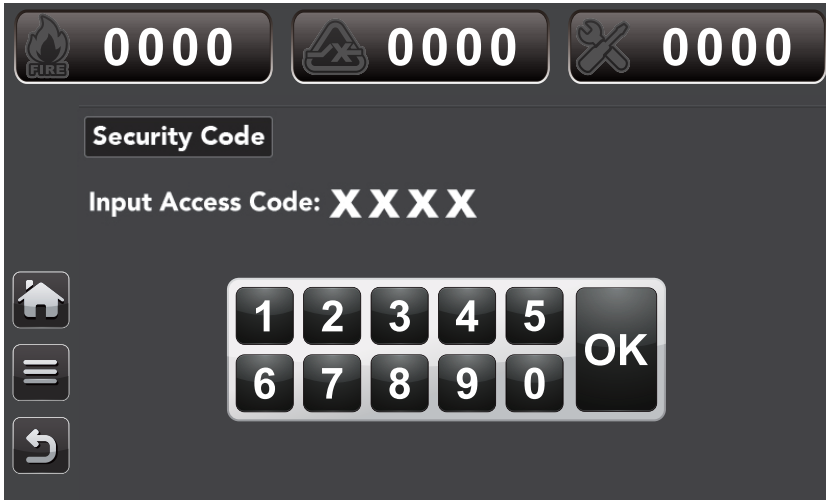

【Figure 1: Screen is ready for Access Code input】

- b. Enter LEVEL 2 Access Code on touch screen or via physical keyboard, if correct, the screen goes to Change Access Code. If incorrect, it will show “ERROR!” as below screen.

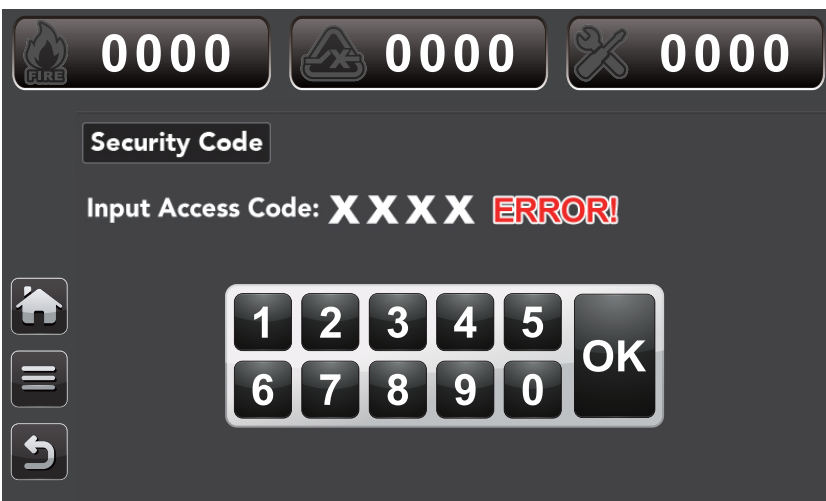

【Figure 2: ERROR! The access code is wrong.】

- c. The screen shows “ERROR!” if the access code is wrong. Please input the correct one and press OK to re-write it.

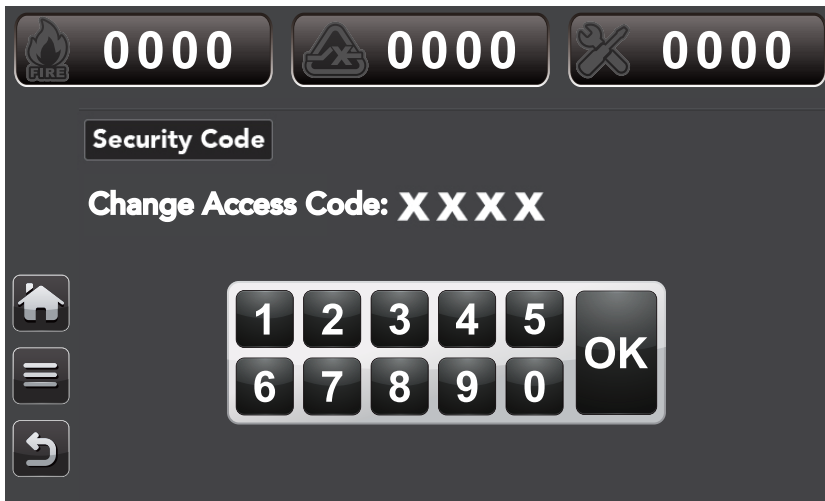

【Figure 3: Screen is ready for Access Code change】

- d. Change a new access code for LEVEL 2 on the touch screen or via physical keyboard and then press OK key to confirm and return to the LEVEL 3 screen.

3. System Wiring Instruction

- (1) Signal wire : 2-core 1.2mm FR-CV wire X 1(S+, S-)
 - ✘ Distance less than 1000m, use 1.2mm wire. Distance greater than 1000m, use 2.0mm.
 - ✘ Signal wire is used with EMT to avoid being affected by other power sources, especially those over AC 100 or 240 V.
 - ✘ Use heatproof(HR) wiring to connect panel to modules.
 - ✘ Wire usage should be in accordance with the local regulation.
- (2) Indicating-lamp wire : 1.6mm X 2
- (3) Bell wire : SND 1.6mm X 2 for bell and buzzer
- (4) AUX-R and AUX power wire : 1.6mm X 2

4. Installation and Testing Notes

- (1) The wires to detectors should not be too close to the installation screw in the detectors to avoid false alarms and low resistance.
- (2) The resistance DC 500V between conventional detector contacts L and LC and ground must be at least 1MΩ.
- (3) The resistance DC 500V between this addressable control panel contacts S+, S- and ground must be at least 2MΩ.
- (4) Use wires with different colors to avoid confusion.
- (5) Keep distance between wires and label wires clearly.
- (6) The total maximum power output is DC 24V 2 A for bell, indicating-lamp and load. Use additional power supply if more than the maximum power output is required.
 - ✘ Please add terminal blocks on each floor to check wires.
- (7) Fuses :

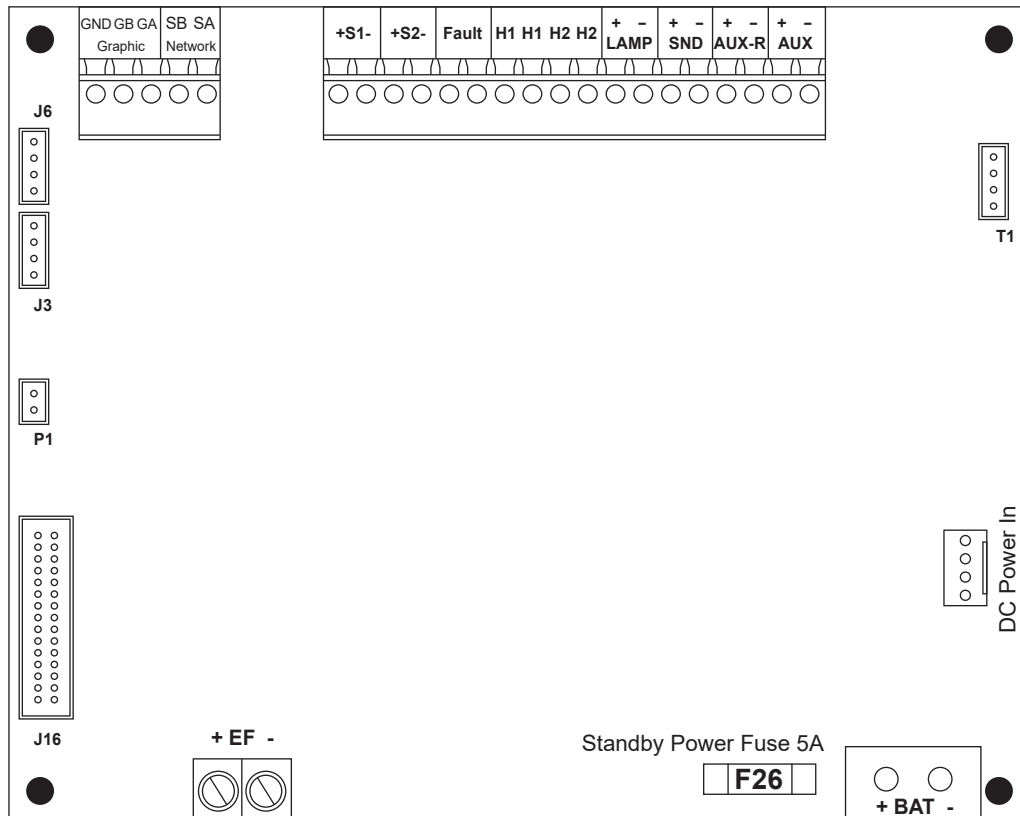

5. Wiring Diagram

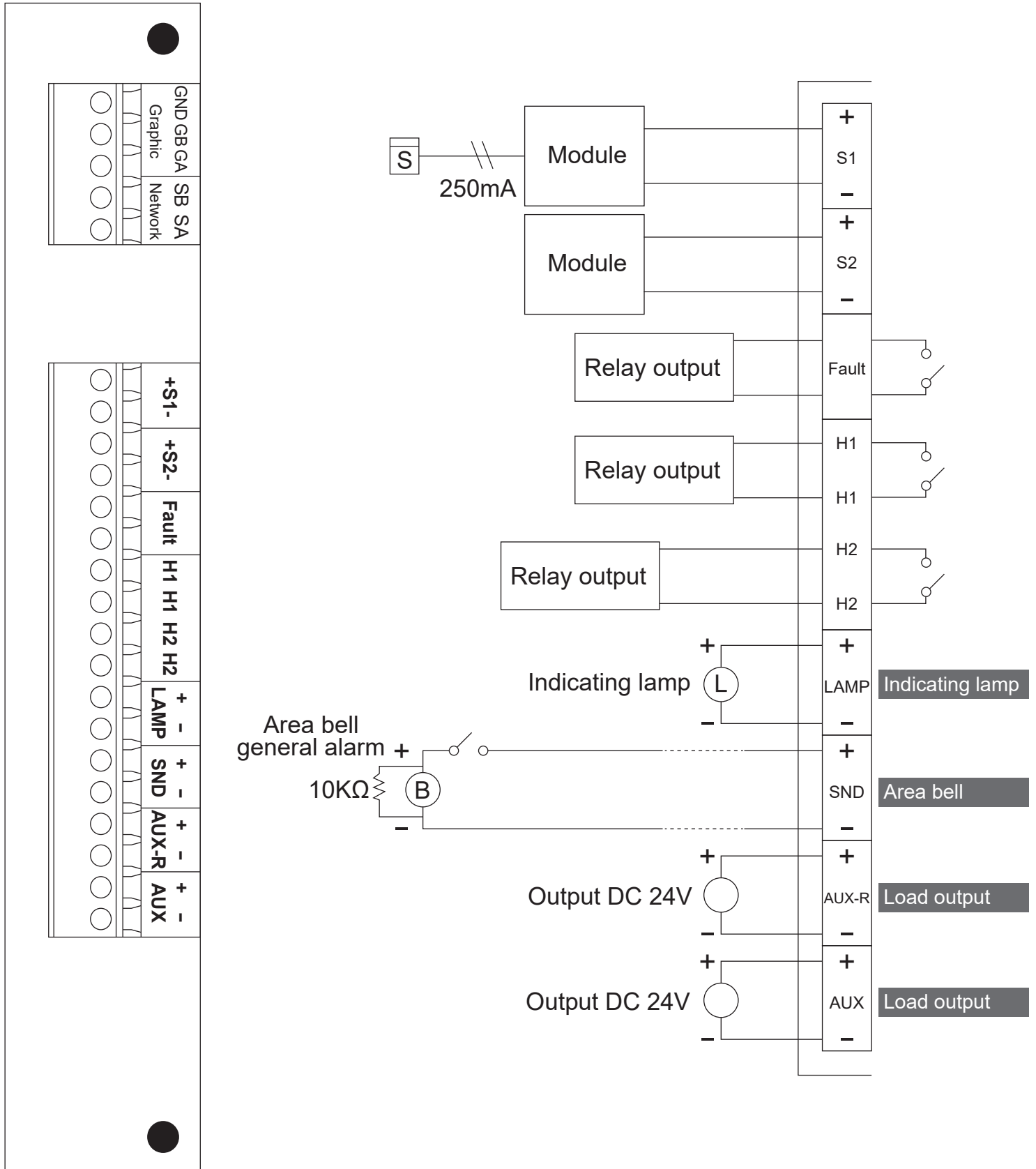

5-1. Detector Wiring

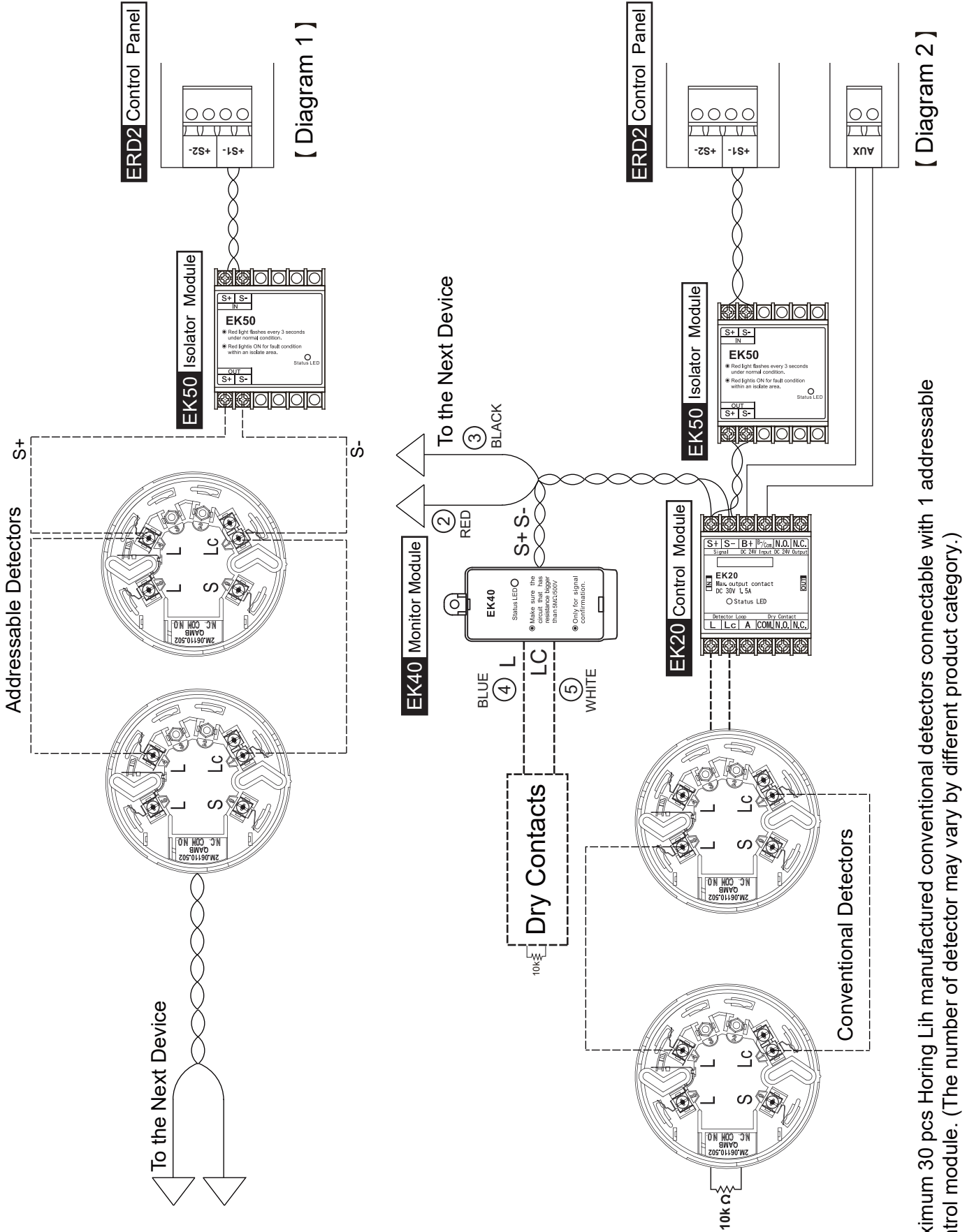

※ Maximum 30 pcs Horing Lih manufactured conventional detectors connectable with 1 addressable control module. (The number of detector may vary by different product category.)

※ Other brands vary by product specification.

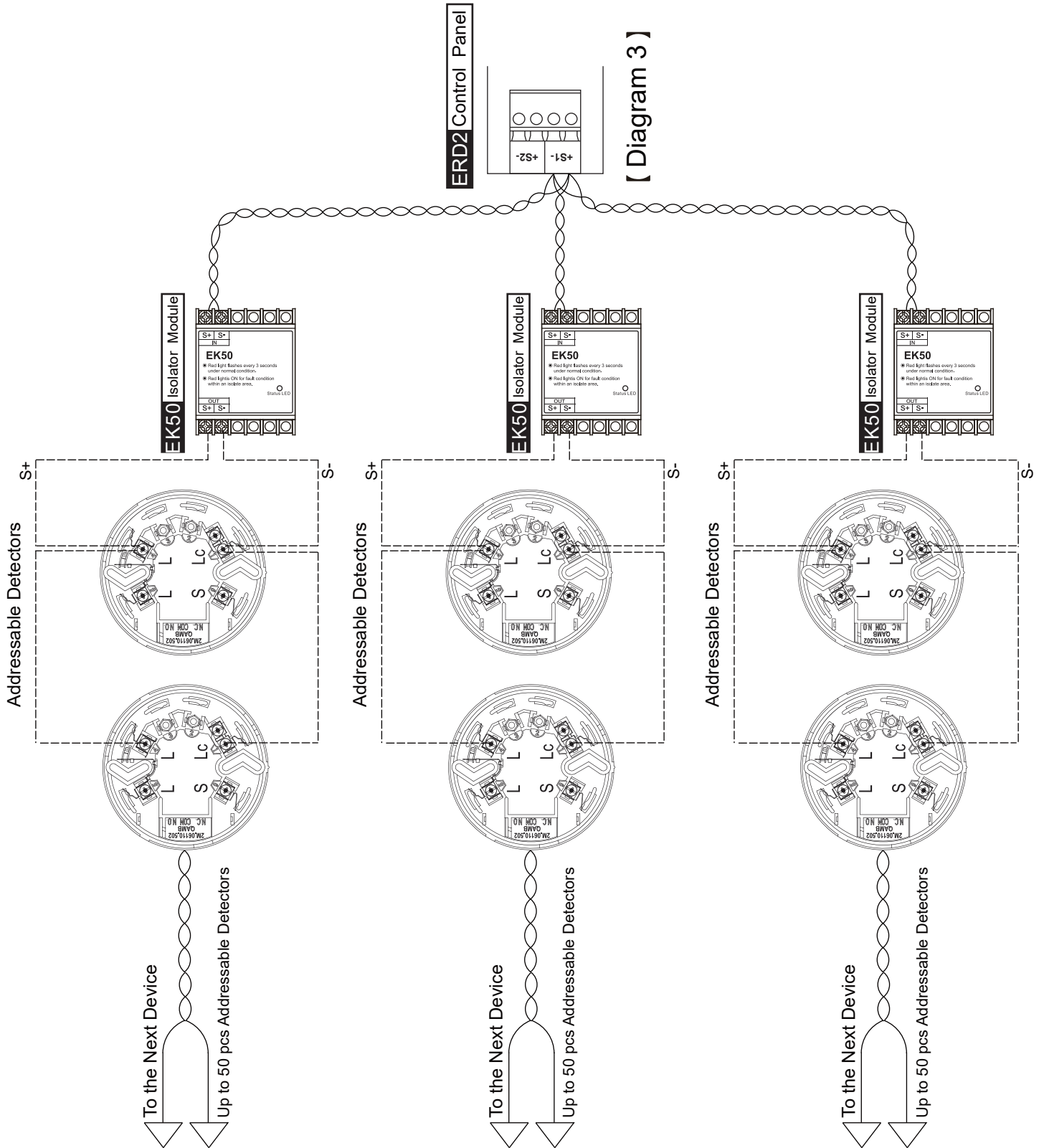

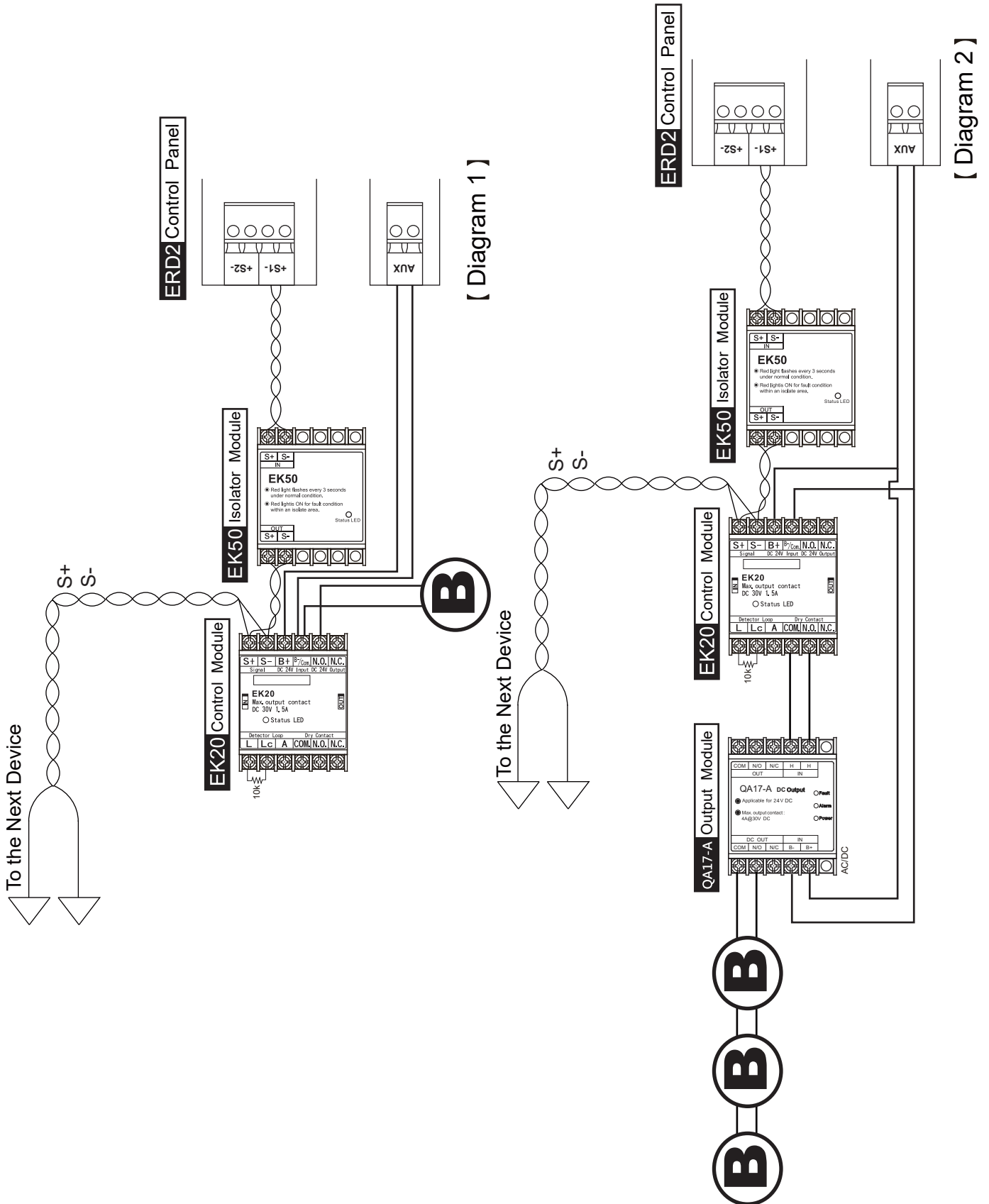

5-2. Area Bell Wiring

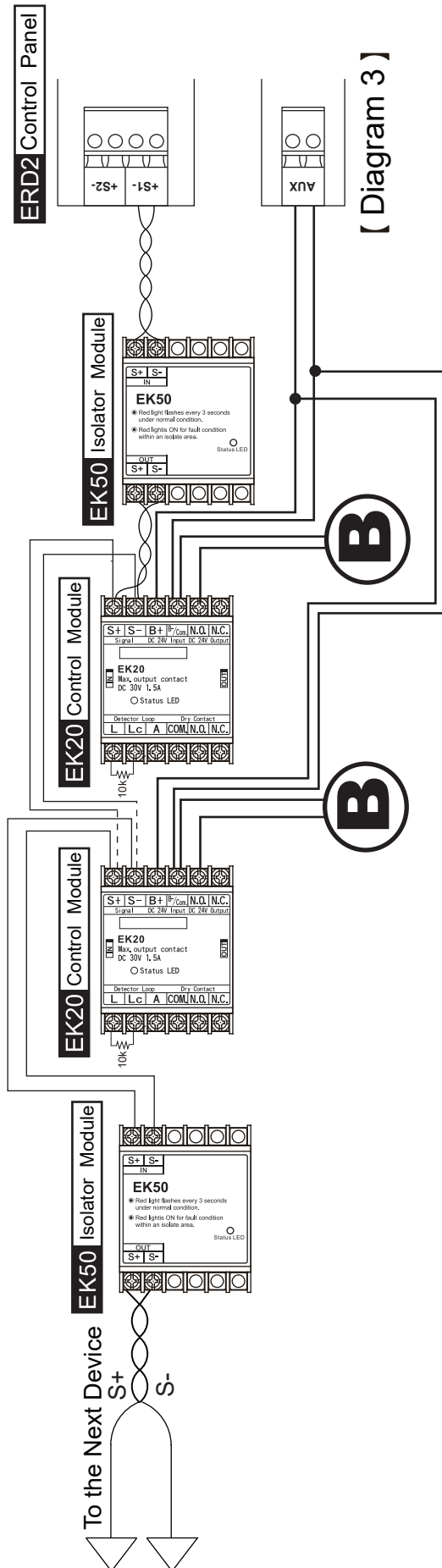

5-3. Manual Call Point Wiring

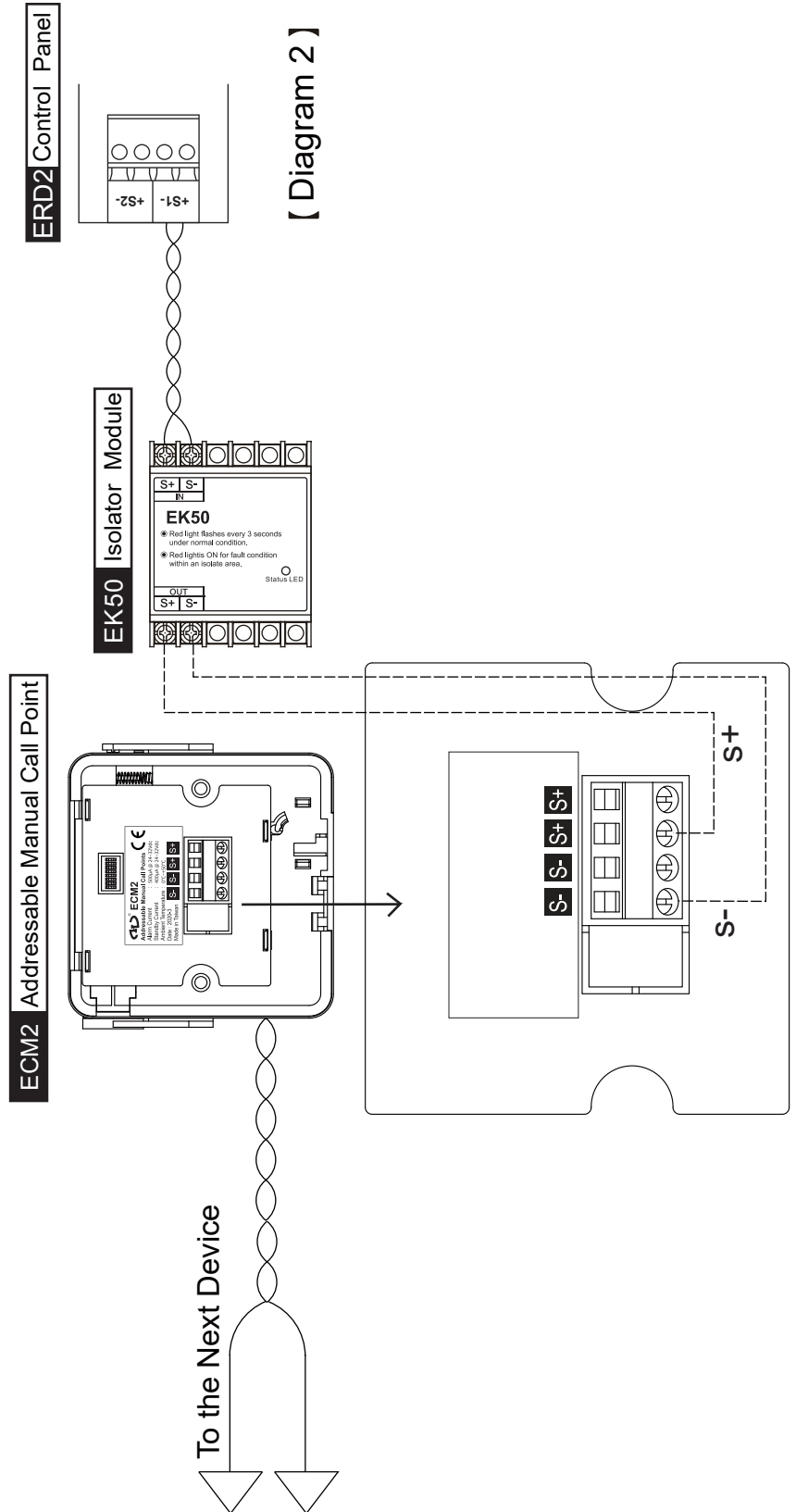
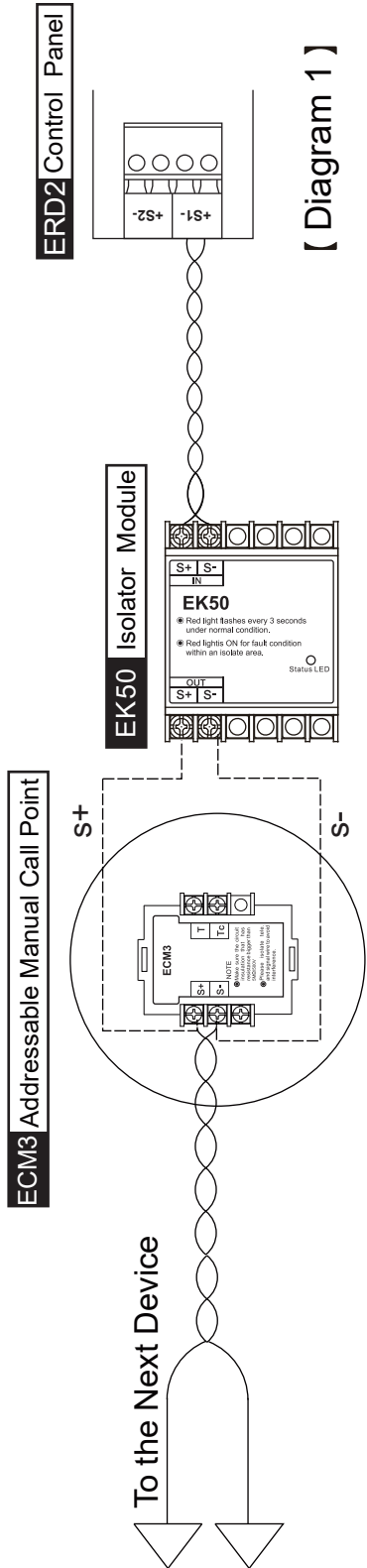

6. Annunciator Wiring

(1) Signal contacts :

Connect the “SA” of the ERD2 control panel to the “SA” of the annunciator .
 Connect the “SB” of the ERD2 control panel to the “SB” of the annunciator.

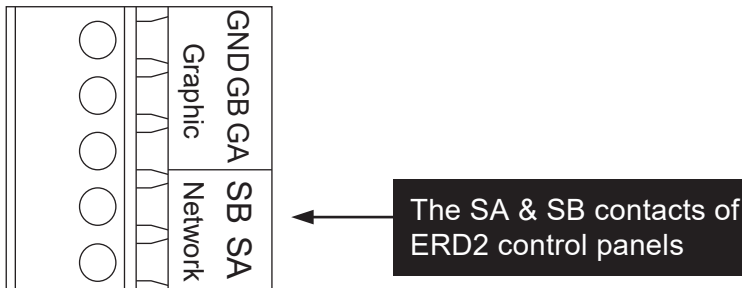

(2) DIP switch settings :

a.(I) ERD2 control panels without annunciators :Please turn down the No.8 at SW4.

(II) ERD2 control panels with annunciators : Please turn up the No.8 at SW4.

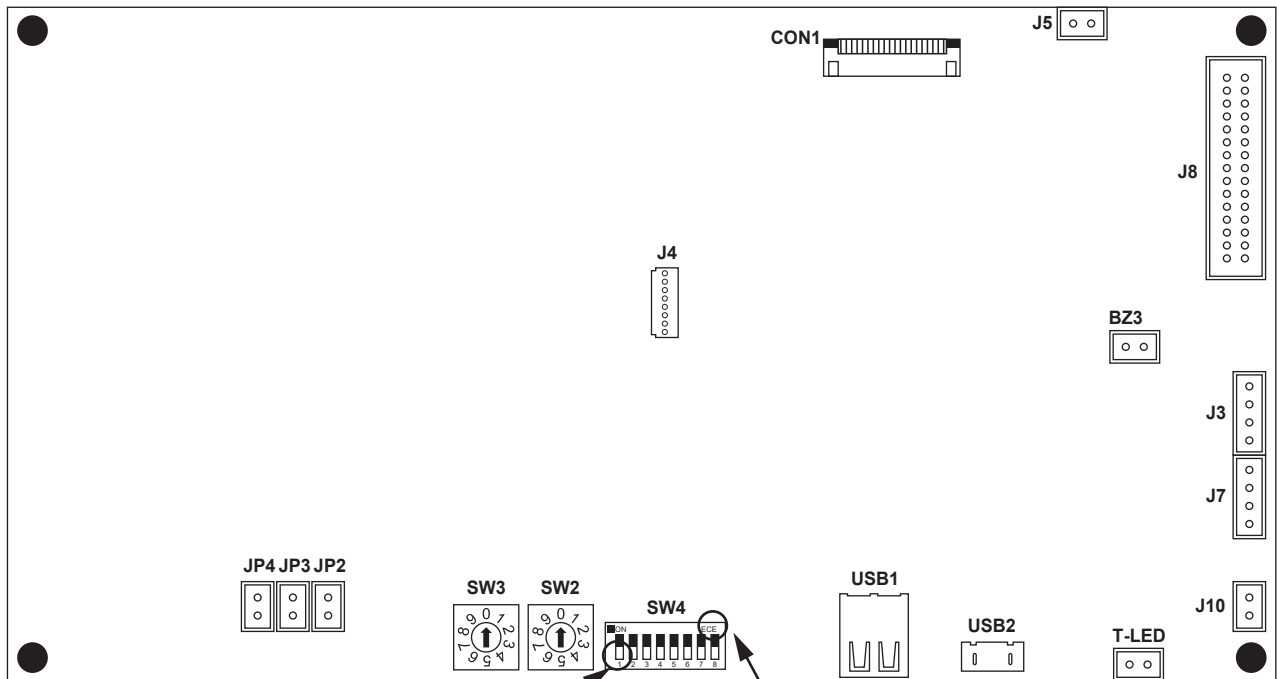

The switch is in white

Rotary Dip Switch on PCB No. ERD2-01

6. Annunciator Wiring

- b. Adjust the panel IP, using SW2 and SW3 to set up the panel IP. SW3 is tens digit and SW2 is unit digit.

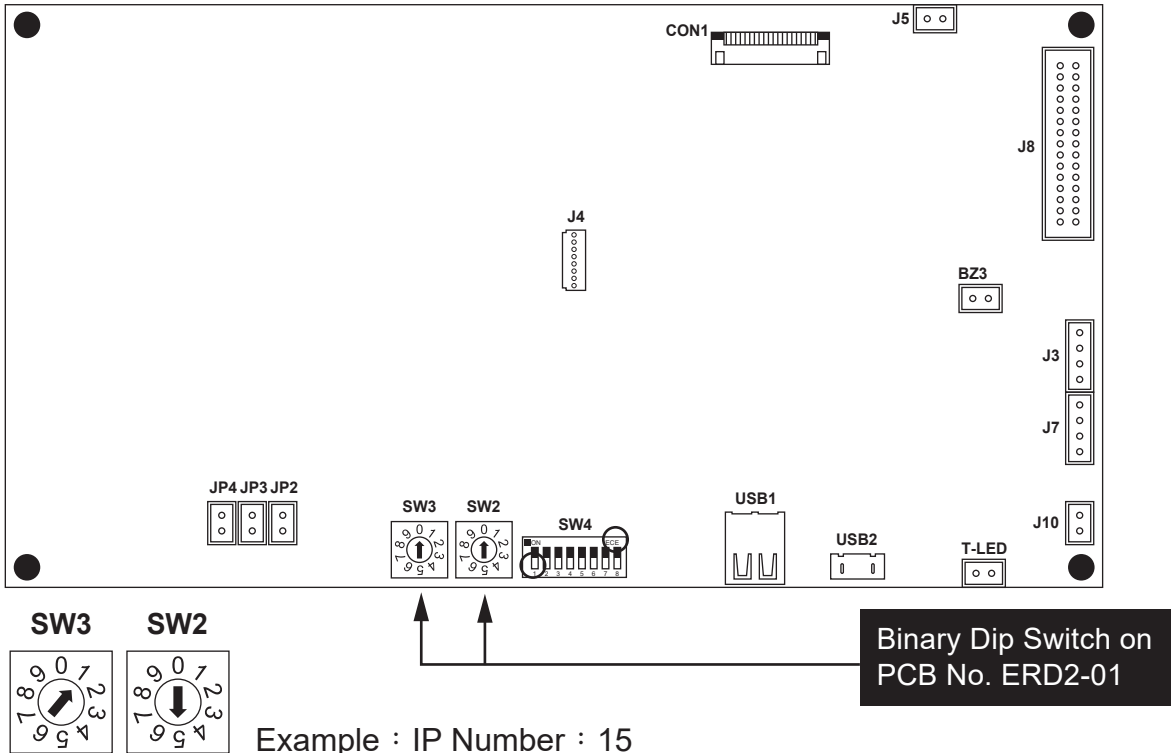

- c. Adjust the total of networking wiring panels , using No.1 ~ NO.6 at SW4 to set up the total of networking wiring panels.

※ The switch is in white

SW4

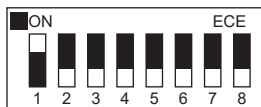

Example :
1 panel

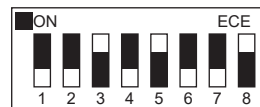

Example :
20 networking wiring panels

“ON” position is “1” and numeric is “0”.

TOTAL NO.	DIP switch	TOTAL NO.	DIP switch	TOTAL NO.	DIP switch	TOTAL NO.	DIP switch
01	10000000	09	10010001	17	10001001	25	10011001
02	01000001	10	01010001	18	01001001	26	01011001
03	11000001	11	11010001	19	11001001	27	11011001
04	11000001	12	00110001	20	00101001	28	00111001
05	10100001	13	10110001	21	10101001	29	10111001
06	01100001	14	01110001	22	01101001	30	01111001
07	11100001	15	11110001	23	11101001	31	11111001
08	00010001	16	00001001	24	00011001	32	00000101

8. Trouble Shooting

ERD2 Basic Problem Shooting Q&A

Q1. The panel cannot be accessed successfully, and the LED turned out to illuminate.

A: 1. There is a problem with burning in the U14 program of the PCB (ERD2-01-B2).

Q2. The panel cannot be accessed successfully, and the screen has frozen up with loop test 0 01 01.

A: 1. Please check the PCB first and decide to replace it with a new one or not.

2. If you find out that the problem with the PCB is IC trouble. This may be the caused by U14.

Q3. The loop board cannot be turned on.

A: 1. Confirm the encoding data if the circuit was check open.

2. After booting up the panel, check if the loop LED3 (LED8), the LED2 (LED6) and the LED1 (LED7) illuminate or not. If not, measure the AC with electricity through.

3. Enter the Selection Menu to see if the loop is open in the LEVEL 2 (7) Loop setting.

Q4. After starting up the panel, the address points are all crashed, but loop failure is not shown on the screen.

A: 1. Check that if the circuit-overload protective lights (LED4 & LED9) are on after supplying the electricity. If "on " is confirmed, it means external circuit has been overloaded or something is wrong with the components in the circuit.

2. Check the fuse F23 (2A fuse) to the PCB is installed well or it has been burnt out.

3. Check the wires S1+ 、 S1- (S2+ 、 S2-) to PCB has come off or not.

4. Measure if the voltage output to the end of wires S1+ 、 S1- (S2+ 、 S2-) and check the LED3 (LED8) is normal or not. The normal voltage should be around 26.5V. However, if it turns out to be 21-24V or even up to 31V, that means not normal and may cause faulty communication.

Q5. The main panel cannot connect to annunciator.

A: 1. Check the dip switch in the IP settings (on the switch board SW2 、 SW3) is turned to the IP number of the panel.

2. Check the rotary switch SW4(8) on the PCB if it is turned to on place.

3. Confirm the total of networking wiring panels at SW4(No.1~7) whether are turn on.

4. Check the encoding data if it has connected to the right number of panels in the network cluster and IP number.

5. Check the SA & SB to the T2 on the PCB if it has come off.

6. Check the heteropolarity of SA & SB of every panel to see if they have connected to one another correctly.

7. Replace the PCB with a new one.

Q6. The LCD is frozen up.

A: 1. Check the switch board CON1 and LCD cable wiring to see if it is fastened well.

2. Replace LCD.

Q7. When operating the panel, and found out there is no reaction, how to tell the panel is in the busy situation or broken down?

A: 1. Confirm the second at right upper corner whether is counting on LCD.

2. Confirm the CPU fault LED whether is light up on panel.

8. Trouble Shooting

ERD2 Basic Problem Shooting Q&A

Q1. The Panel turned on abnormally, all LED lights of control board are ON?

- A: 1. U14 IC on CPU board may be not installed well or it has program fault.
2. Check power supply are normal and all bridge cables between circuit boards are fixed well.

Q2. The Loop is disable or showed Loop fault?

- A: 1. Check LED2 is flash on Power Loop Board, if not, please check the bridge cable and communication IC between Power Loop Board and CPU board.
2. Check LED25(LED26) is lit steady, if not, please enter Loop Setting (in LEVEL 2) to enable the loop.
3. Verify the programming data on Loop Setting.

Q3. All addressable point show fault, but no loop fault?

- A: 1. Check S1 and S2 wired normal.
2. Check LED25(LED26) is lit steady, if not, please enter Loop Setting (in LEVEL 2) to enable the loop.
3. Verify the programming data on Loop Setting.
4. Check fuse F1 and F16 (0.3A Fuse) on Loop Power Board. The fuse may be overheated or burnt caused by short circuit in the external wiring, please check and replace a new one.
5. Measure output voltage of S1 and S2 is between 24~32V. Voltage lower than 24V and higher than 32V are abnormal.

Q4. Connection failed between the Panel and Annunciator?

- A: 1. Check IP rotary dipswitch SW2 and SW3 on CPU Board if they are correct IP number.
2. Check binary dipswitch SW4, position 8 is turned upward.
3. Check binary dipswitch SW4, positions 1~6 are set in correct total network number.
4. Check programming data is multiple IP setting.
5. Check network contacts, SA and SB on Power Loop Board are fixed well.
6. Check the polarity for all panels' network contacts, SA and SB are correct.
7. Replace CPU Board.

Q5. Panel LCD display failed?

- A: 1. Check bridge cable and contact CON1 on CPU Board are fixed well.
2. Replace LCD or LCD Board.

Q6. When Panel has no reaction during operating, how to tell it is busy or breakdown?

- A: 1. Check time on LCD screen is changing, there is still running.
2. If time on LCD screen stopped running, and CPU Fault LED lit, please replace the CPU Board.

8. Trouble Shooting

ERD2 Basic Problem Shooting Q&A

Q7. Standby power failure?

- A: 1. Check battery wire connection and the power cord condition.
2. Check standby power fuse F26 (5A). Remove the fuse to measure whether it is circuit break, if it is, replace the corresponding fuse.
3. Switch off AC power and then measure whether the battery terminal has 24VDC or higher output. If not, please replace a new battery.

Q8. Panel Fault LED is ON?

- A: Review the fault event on touch screen LCD and troubleshoot the cause of fault.

Q9. Panel has no respond to activation of connected conventional device?

- A: 1. Check the wirings and terminal of S1 and S2, whether they are loosening or wrongly connected.
2. Check if the alarm LED on addressable module is lit.
3. Replace another addressable module to find out if any damage.
4. Check whether the alarm current of the conventional device is too large, causing the action to fail.

Q10. Fire Indicating Lamp is not ON?

- A: 1. Check whether the bulb/LED of the fire indicating lamp is burnt out.
2. Check whether the wiring between panel and fire Indicating lamp is loosen.
3. Check fuse F4, whether the fuse is overheating tripped, if it is, LED17 will lit means the external wire is short-circuited or overloaded, please check maximum output current specification again.

Q11. Alarm Bell does not sound? (SND)

- A: 1. Check the bell switch on panel if it is OFF.
2. Check whether the wiring of alarm bell and panel terminal is loosening.
3. Check the bell condition and wiring connected are correct.
4. Check whether the bell connected addressable module is activated.

Q12. Panel buzzer does not sound?

- A: 1. Check the switch on panel if it is OFF.
2. Check whether no power supply to CPU Board.
3. Check bridge cable of BZ3 on CPU Board is fixed.
4. Check whether the buzzer is faulty, if it is, please replace one.

Q13. Addressable Detector has false alarm?

- A: 1. The detector is affected by dust, please perform maintenance.
2. The detector is abnormal, please replace another one and test.
3. Check the wire of S1 and S2, whether any cross-over wiring happened.

8. Trouble Shooting

ERD2 Basic Problem Shooting Q&A

Q14. Conventional detector has false alarm?

- A: 1. The detector is affected by dust, please perform maintenance.
2. The detector is abnormal, please replace another one and test.
3. Remove the external wires of L+/L- from connected addressable module, and test if the module is short circuited or grounded. If the module is normal, please troubleshoot the short circuit or ground from external wire.

Q15. Addressable Heat Detector has false alarm?

- A: 1. The detector may be faulty or abnormal, please replace one and test.
2. Great change of ambient temperature and high humidity.
3. Check the wire of S1 and S2, whether any cross-over wiring happened.

Q16. Conventional Heat Detector has false alarm?

- A: 1. The detector may be faulty or abnormal, please replace one and test.
2. Great change of ambient temperature and high humidity.
3. Remove the external wires of L+/L- from connected addressable module, and test if the module is short circuited or grounded. If the module is normal, please troubleshoot the short circuit or ground from external wire.

9. The SOP for Troubleshooting the Cluster Network.

(A) Confirm each fire alarm panel is in the normal state.

Test and inspect every fire alarm panel respectively.

- ① Cut off the power supply.
- ② Disconnect the wires connected to SA & SB in the panel (Network).
- ③ Turn the rotary switch SW4(NO.8) to ON.
- ④ Confirm the total of networking wiring panels at SW4(No.1~6) whether are correct.
- ⑤ Make certain that the IP address code of the DIP (SW2、SW3) on the control board is correct.
- ⑥ Test if there is any short circuit between every terminal and the earth.
- ⑦ Test if there is any short circuit in the positive and negative poles in every DC power supply.
- ⑧ Supply the fire alarm panel with power.
- ⑨ Make sure that the IP address in upper left screen can be displayed correctly when the switch is on. It must correspond with the settings of DIP (SW2、SW3).
- ⑩ Check if the output voltage in every DC power supply is normal.
- ⑪ Test one operating unit to see if it can operate properly without any malfunction.

(B) Make sure that the external wiring to the end-of-line SA, SB is normal.

- ① Test if there is any earthing short circuit occurred between the end-of-line SA, SB and the earth.
- ② Test if any short circuit come about between the external wire SA and the external wire SB.
- ③ Test if terminal SA, SB through every terminal block are connected.

(C) Cluster Network Restoration

- ① Shut down the fire control panel and connect to SA & SB (Network). We suggest it is better to network the cluster respectively. As a result, please network to the 1st panel first. (There must exist the 1st panel)
- ② Turn on the fire control panel. After confirming that the 1st and 2nd one can perform well, turn the switch from on to off respectively, connecting one to one another (Network), and supply power.

10. The Steps to Remove Network Troubles

(A) Confirm that one operating unit is in the normal condition.

1. Shut down the fire control panel, disconnect the AC wires on the control board and switch off the power supply.

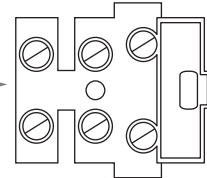
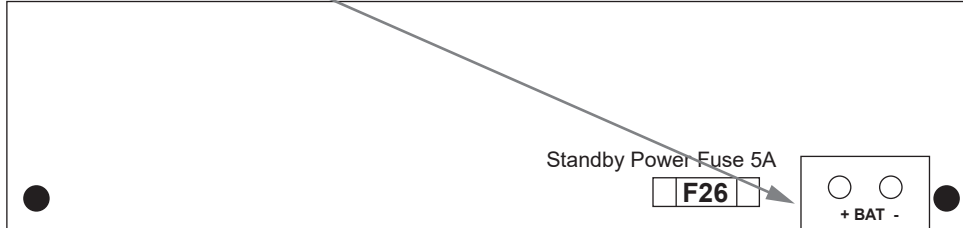

And test that AC voltage input is normal or not. (110V/220V)

※ (please refer to the IP address code on SW2,sw3 to determine the right location)

4. Confirm the total of networking wiring panels at SW4(No.1~6) whether are correct.

3. Turn the rotary switch SW4(No.8) to off, and it should be set up to the standalone version.

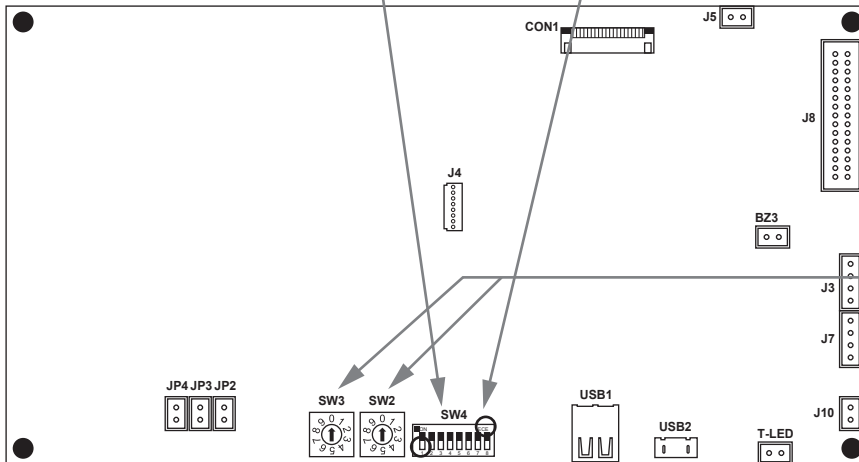

5. Make certain that the IP address code of the DIP (SW2.SW3) on the control board is correct.

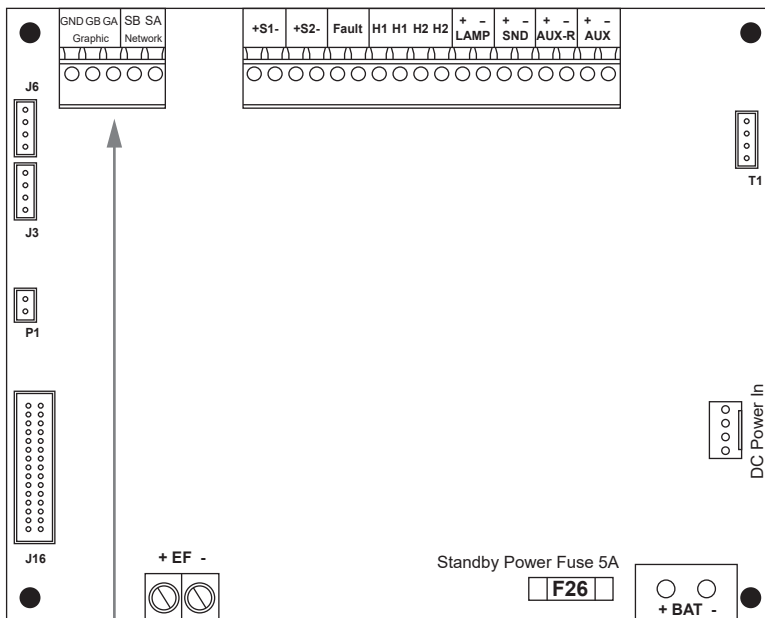

2. Disconnect the end-of-line SA & SB on the annunciator (RS485-1).

10. The Steps to Remove Network Troubles

(A) Confirm that one operating unit is in the normal condition.

6. Test if there is any short circuit between every terminal and the earth.

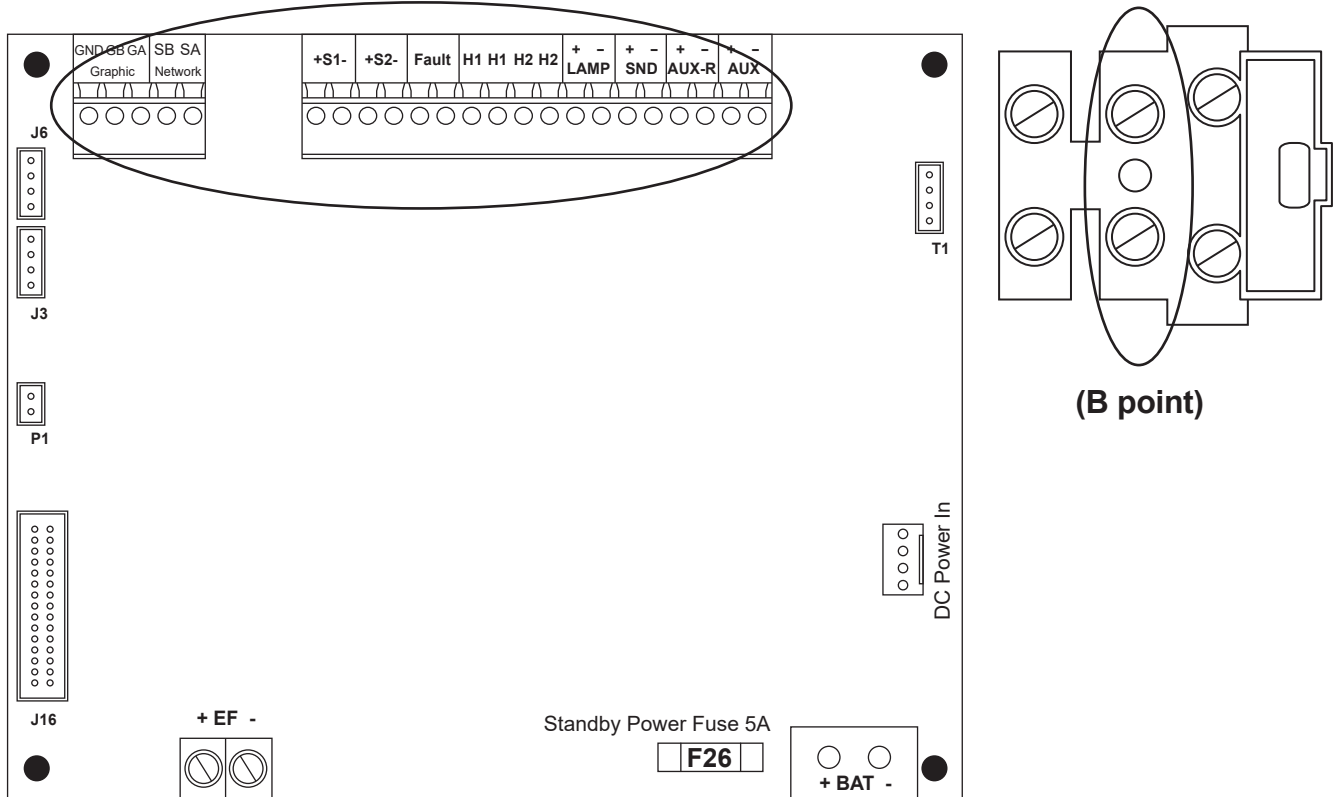

- (1) Test if there is any short circuit between every terminal (A point) and the earth (B point). (earthing short circuit)
- (2) If any short circuit happened, please disconnect all the external wiring at A point and test again to clarify that the problem is external wiring earthing or broken panel earthing.
 - (2-1) After disconnecting external wiring, please give A point a test. If no earthing short circuit happened, we can attribute it to external wiring earthing. In this situation, test every external wire connected to the earth to narrow down which wire exists short circuit and then remove it.
 - (2-2) After disconnecting external wiring, test A point. If there still exists short circuit, please follow the procedure as below to isolate faults to find out which board caused earthing short circuit:
 - (a) Disconnect all the wires connected to the control board and the seven-segment display & wires connected to the control board and the key switch board. Test again all the terminal blocks in the control board and the earth. If an earthing short circuit is attributed to the control board, please replace it at once.

10. The Steps to Remove Network Troubles

(A) Confirm that one operating unit is in the normal condition.

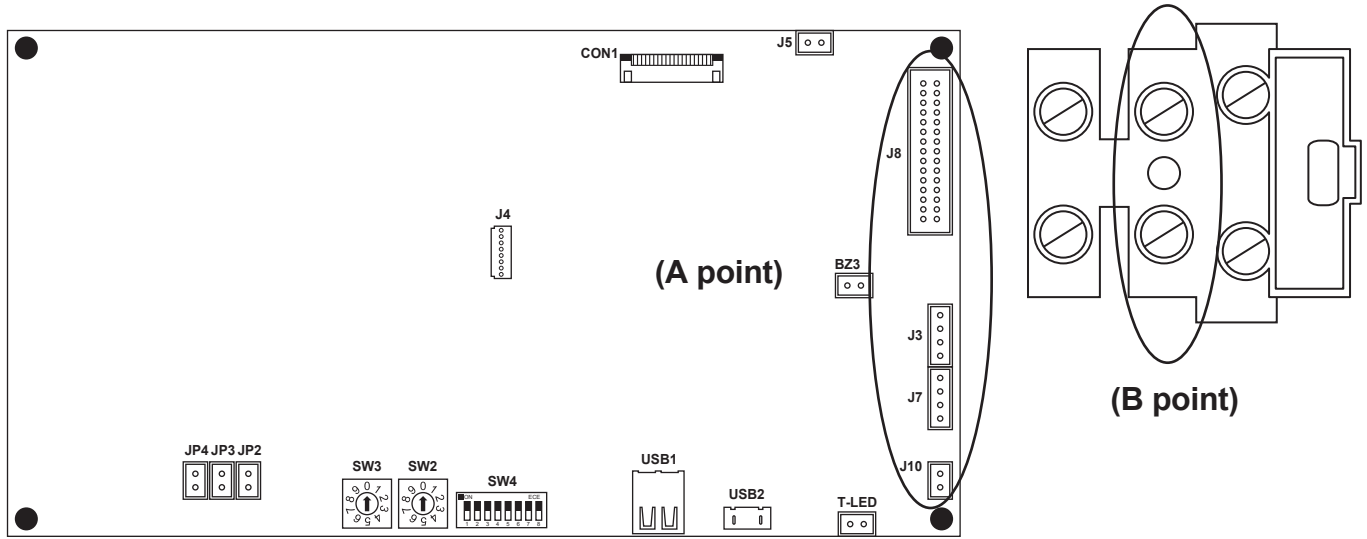

- (b) If it is not caused by (a) mentioned above, it might be caused by the key switch board. In this situation, please disconnect all the wires (A point) to which the key switch board is connected and measure all the terminal blocks and earthing points (B point) connected to the key switch board. If any short circuit is determined somewhere, please replace the key switch board immediately.
- (c) If there is no earthing short circuit in the key switch board, LCD and seven-segment display are suspect, please overhaul if there is any short circuit occurred in the circuitry between the terminals and the earthing. After identification, please do the replacement.

10. The Steps to Remove Network Troubles

(A) Confirm that one operating unit is in the normal condition.

7. Test if there is any short circuit in the positive and negative poles in every DC power supply.

In the following illustration, we can see ▲ is a positive pole and ▼ is a negative pole. Disconnect all the wires and test them respectively if there is any short circuit occurred in the positive or negative pole. Once short circuit come about, please replace the control board directly.

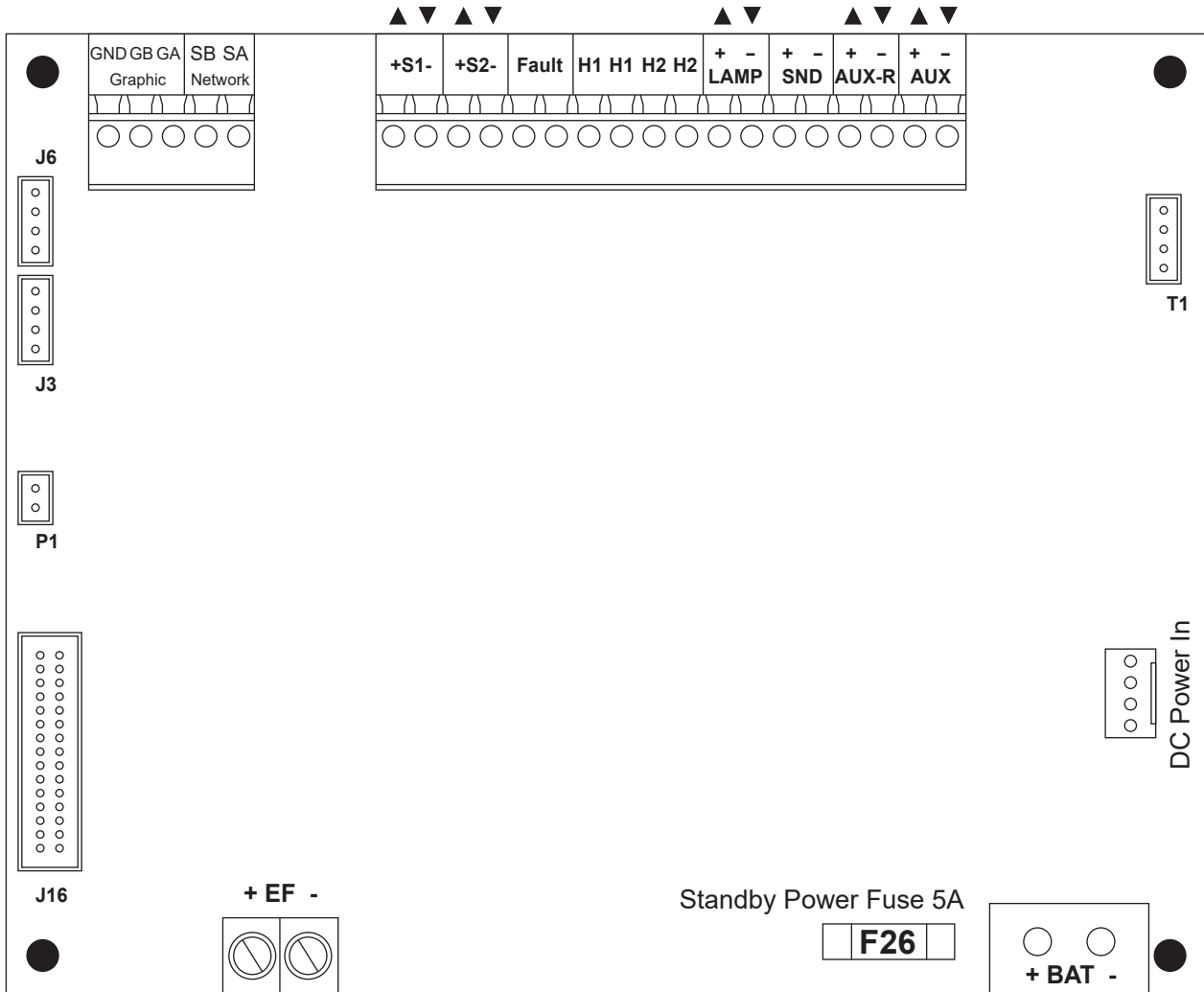

10. The Steps to Remove Network Troubles

(A) Confirm that one operating unit is in the normal condition.

※Please re-connect the internal wiring in the panel if disconnection has been performed

8. Supply the fire alarm panel with power.

9. Make sure that the IP address in upper left screen can be displayed correctly when the switch is on.

It must correspond with the settings of DIP (SW2.SW3). If not, please re-download an encoding or adjust the IP settings of the DIP (SW2.SW3).

10. The Steps to Remove Network Troubles

(A) Confirm that one operating unit is in the normal condition.

10. Check if the output voltage in every DC power supply is normal or not. If any fault occurred, please ensure that all the fuses are in the good condition. Burned out fuses need to be replaced and if they all turned out to be normal, then please replace the control board or power supplies.

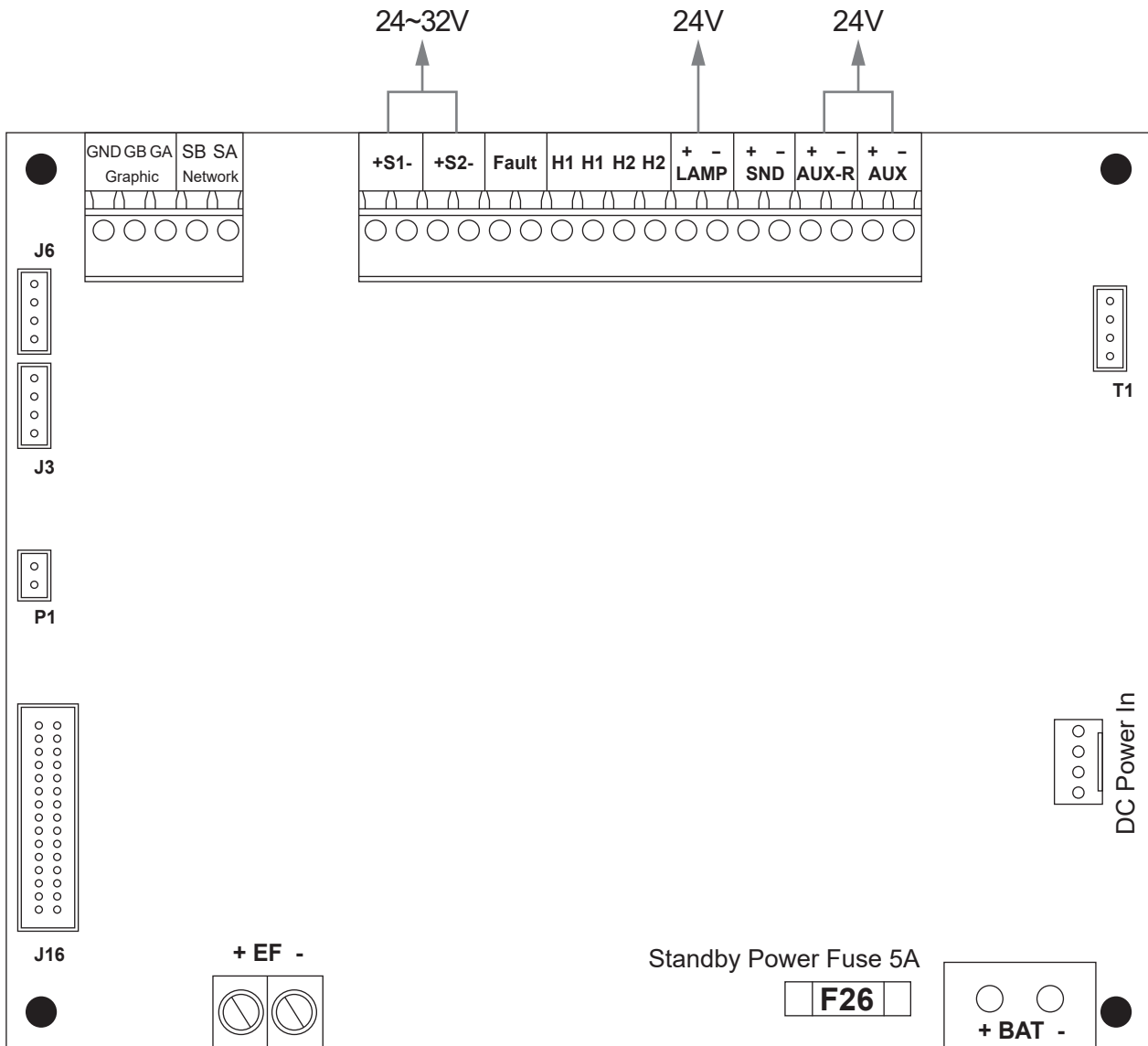

11. When 1~10 steps are confirmed to be correct, please test one operating unit to see if it can operate properly. If there is no other way repairing, please replace the board with a new one.

10. The Steps to Remove Network Troubles

(B) Make sure that the external wiring to the end-of-line SA, SB is normal.

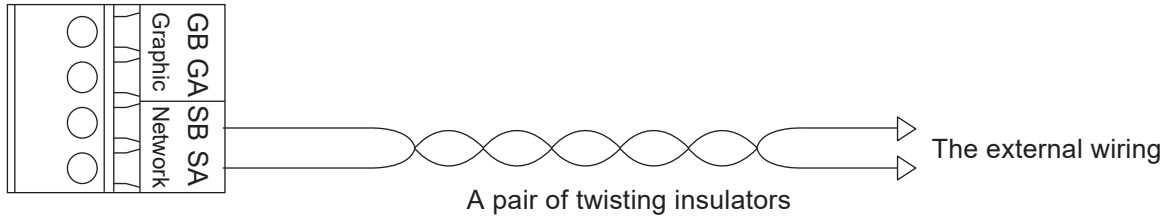

1. Test if there is any earthing short circuit occurred between the end-of-line SA, SB and the eath.
2. Test if any short circuit come about between the external wire SA and the external wire SB.

(C) Cluster Network Restoration

1. Shut down the fire control panel and connect to SA & SB (Network). We suggest it is better to network the cluster one by one. As a result, please network to the 1st panel first. (There must exist the 1st panel)
2. Turn on the fire control panel. After confirming that the 1st and 2nd one can perform well, turn the switch from on to off respectively, connecting one to one another (Network), and supply power.



HORING LIH INDUSTRIAL CO., LTD.

Addressable System

Operating Manual