



# R TYPE INTELLIGENT FIRE ALARM SYSTEM

—USER'S GUIDE—

HORING LIH INDUSTRIAL CO., LTD



CNS

ISO 9001

## CONTENT

1. General	1
2. Configurations	2
3. Descriptions of Surface Board	3
4. Descriptions of LED Display & Control Switch	4
5. Operation Instructions	
A. System Display Zone of Distributed Function	5
B. LCD Screen	5
C. Function Status Indicator	5~6
D. Function Defect Indicator	6
E. Function Test Device	6
F. Function Control Device	6
G. System Functions	6~7
6. Module Types	7
7. Maintenance	
A. Control Panel	7
B. General	7
8. Simple Fault Elimination	8

## 1. General :

R-type intelligent fire alarm system is an alarm transmission system that consisted by design control of micro- computer, its structure includes hardware and software that is a completed protection net formed by R-type fire alarm control panel, addressable module, addressable detector, conventional detector and relevant simultaneous control facility of fire prevention monitoring. This system is able to issue pre-alarm at early stage of real fire, automatically activate related fire fighting facilities and quickly notify the Fire Prevention Center for effective handling when building has fire situation.

The designation, manufacturing, inspection and test of this fire alarm system are all comply with latest version standards and regulations as following :

- A. Chinese National Standard (CNS)
- B. Fire-fighting and relevant Code
- C. Fire-fighting safety Installation Standard for various location

For various country standards, systems modification is also available.

## 2. Configurations :

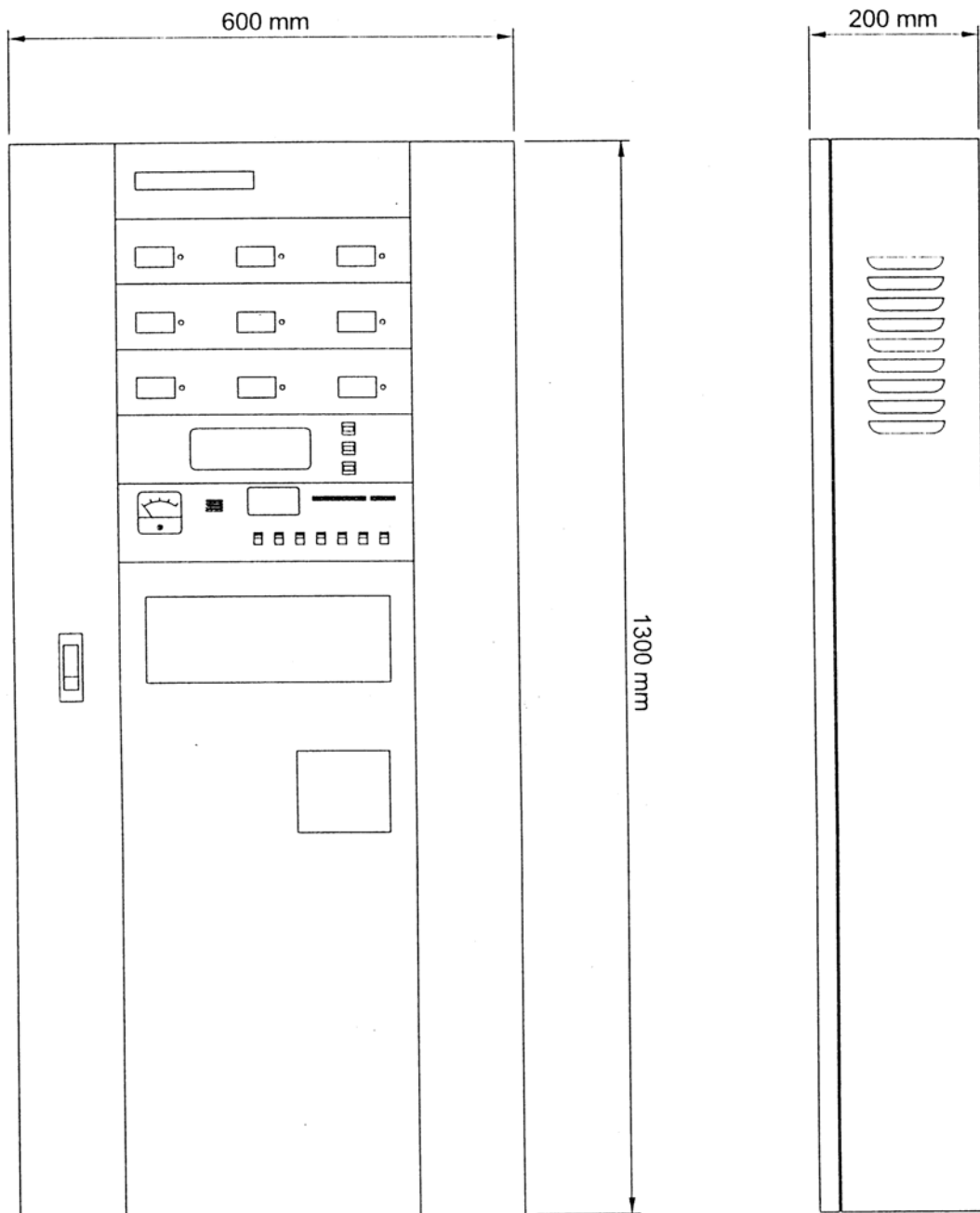

### 3. Descriptions of Surface Board :

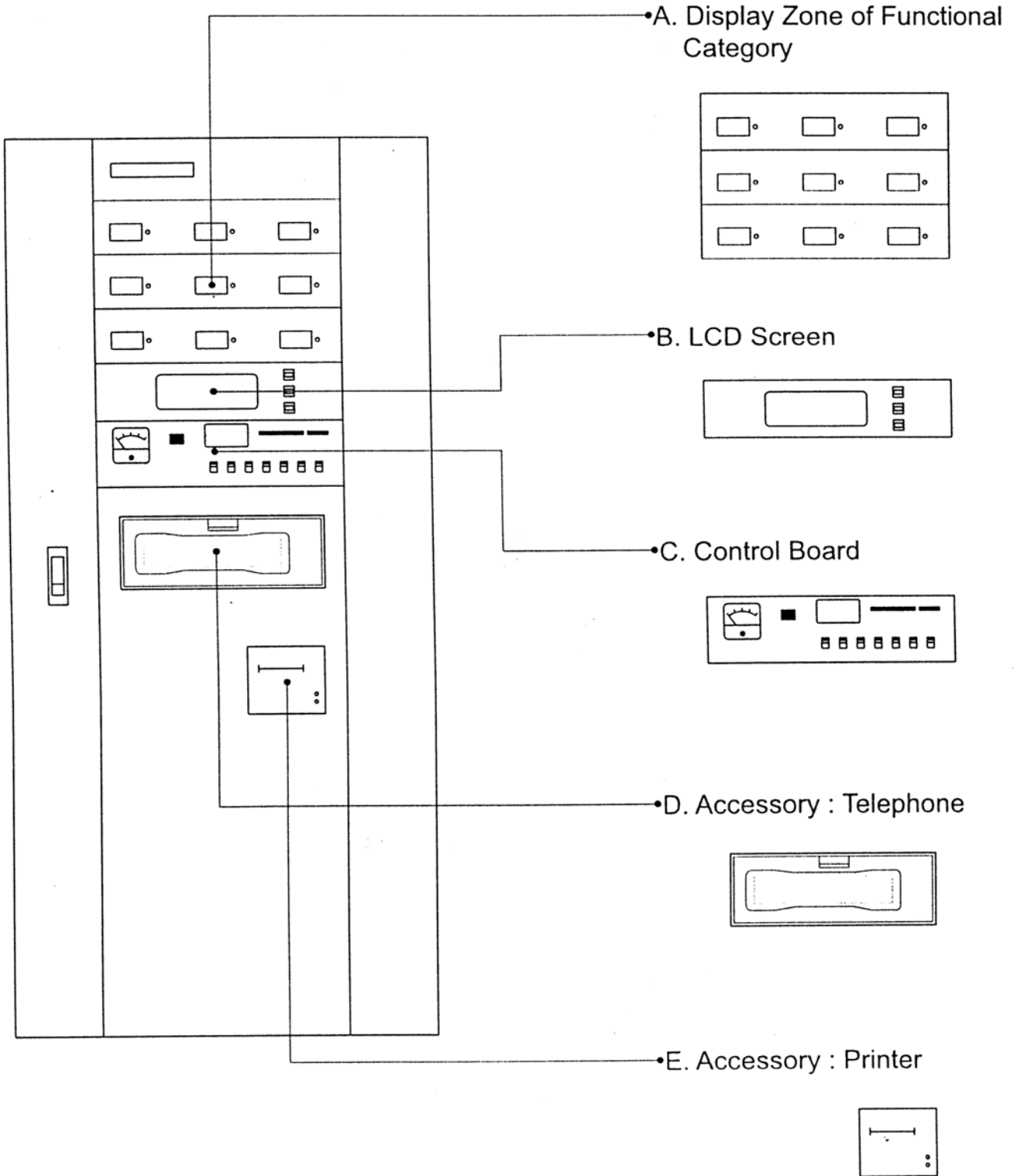

## 4. Descriptions of LED Display & Control Switch :

### A. Display Zone of Functional Category

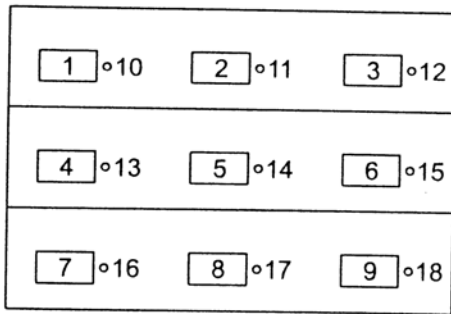

1	Total zones of alarm activation
2	Total zones of disconnection
3	Total zones of fault
4	Total zones of evacuation activated
5	Total zones of disconnection
6	Total zones of fault
7	Total zones of sprinkler activation
8	Total zones of disconnection
9	Total zones of fault
10	Zone inquiry of alarm activation
11	Zone inquiry of disconnection
12	Zone inquiry of fault
13	zone inquiry of evacuation activated
14	zone inquiry of disconnection
15	zone inquiry of fault
16	zone inquiry of sprinkler activation
17	zone inquiry of disconnection
18	zone inquiry of fault

### B. LCD Screen

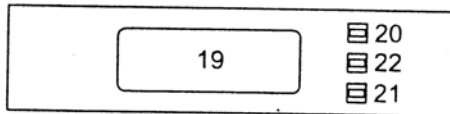

19	LCD screen
20	Previous page
21	Next page
22	Total review

### C. Control Board

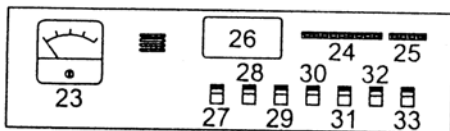

23	Voltmeter
24	AC indicator
	Battery indicator
	Disconnection indicator
	Attention switch indicator
	Manual call point indicator
	Telephone indicator
	Water shortage indicator
	Water drawing indicator
	Pump indicator
25	AC power fault indicator
	Battery power fault indicator
	Module power fault indicator
	Load power fault indicator
26	Fire indicator
27	Main sound
28	Area sound
29	Simultaneous activation
30	Battery test
31	Load power test
32	Accumulation switch
33	Reset switch

## 5. Operation Instructions :

### A. System Display Zone Of Distributed Function

#### a. Fire Alarm Display Zone (activation, disconnection, fault)

When field conventional type detector or manual call point start activation , alarm signal will be sent to control panel via module. However, addressable detector or manual call point could directly send alarm signal to control panel. Loop disconnection and fault signal are transmitted the same way as activation. The condition of module will be showed on display zone, its total event # is showed by number, press the inquiry button for priority condition handling.

#### b. Smoke Evacuation Display Zone (activation, disconnection,fault)

when field conventional type detector or manual call point start activation, alarm signal will be sent to control panel via module. However, addressable detector or manual call point could directly send alarm signal to control panel. Loop disconnection and fault signal are transmitted the same way as activation . The condition of module will be showed on display zone, its total event # is showed by number, press the inquiry button for priority condition handling.

#### c. Sprinkling Display Zone (activation , disconnection,fault)

When field sprinkler or foam alarm valve start activation, alarm signal will be sent to control panel via module.

The condition of module will be showed on display zone, its total event # is showed by number, press the inquiry button for priority condition handling.

### B. LCD Screen

When any event happens, LCD will immediately show the location, date, time, module address, alarm status and # of events in English. If several events happened at same time, press the inquiry button for emergency condition to save the time on data checking.

a. Use [Previous page] [Next page] to read before and after the current data.

b. [Previous page] + [Total review] to check operation status, loop number and module number.

c. [Next page] + [Total review] to check the latest 256 history data.

d. [Previous page] + [Next page] will show 4 selections (two data print out ) (all data pring out ) (record data delete) (exit), clear and easy to operate.

### C. Function Status Indicator

#### a. AC indicator

When it is light up, the control panel is under normal power condition.

#### b. Battery Indicator

Control panel equipped with auto charging device and battery. When main power is off, the input power will switch to battery power, thus [Battery indicator] will on and [AC indicator] will off.

#### c. Disconnection Indicator

This control unit has function of "Auto Loop Disconnection Display". If any loop or end-of-line resistor has disconnection situation, [Disconnection indicator] & [Display Zone] will blink, Disconnection Sound will active. The above condition will release automatically after loop connection back to normal.

#### d. Attention Switch

If any of control switch is not in position, [Attention switch indicator] will blink. This signal will disappear when all control switches are in position.

#### e. Manual Call Point Indicator

When [Manual call point Indicator] lights up, it means control panel will active immediately without any delay by accumulation function.

#### f. Telephone Indicator

This control unit is designed with communication device. Plug one portable phone set into field manual call point, the [Telephone indicator ] will lights up and buzzer will sound. Pick up the phone on control unit, buzzer sound will stop and then both sides can start communicating. When telephone back to original location, the signal will reset automatically.

#### g. Water shortage Indicator

#### h. Water Drawing Indicator

i. Pump Indicator

j. Fire Indicator

When any detector or manual call point activates, [Fire indicator] , [Display Zone] and [LCD screen] will light up and display, main sound and Alarm bell will activate, indicating lamp will become flash from steady light.

D. Function Defect Indicator

a. AC Power Fault Indicator

Indicates the AC power fuse is burnt, and most possibility of causes are external wiring error, short circuit or defect external device. Check out the real cause before replacement.

b. Battery Power Fault Indicator

Indicates the Battery power fuse is burnt, and most possibility of causes are external wiring error, short circuit or defect external device .Check out the real cause before replacement.

c. Module Power Fault Indicator

Indicates the Module power fuse is burnt, and most possibility of causes are external wiring error, short circuit or defect external device. Check out the real cause before replacement.

d. Load Power fault Indicator

Indicates the Load power fuse is burnt, and most possibility of causes are external wiring error, short circuit or defect external device. Check out the real cause before replacement.

E. Function Test Device

a. Battery Test Switch

Control panel should maintain the AC power source during normal operation. To verify the battery whether it is in good condition, just press [Battery test] and read the voltage value from [Voltmeter].

b. Load Test Switch

Control panel basically equipped with 2 sets of battery for system and DC load power. Press [Load power test] and read voltage value from [Voltmeter] to verify its normal power output.

F. Function Control Device

a. Main Sound Switch

Use different frequency of sound to distinguish activation, disconnection, defect of module and various condition of control panel . The designation of revertible switch could temporary turn off the sound from control panel , but it will sound again when received new alarm signal. Thus, control panel could remain alert status during the process of function test.

b. Area Sound Switch

When alarm activation process the preset system simultaneous program & output address instruction, the alarm bells or buzzers will be energized. External output could be closed by press the [Area Sound] switch.

c. Simultaneous Activation Swtich

Alarm bell could active simultaneously or on certain floor as request.

d. Accumulation Switch

This function is to minimize false alarm that caused by pulse or messy signal.

e. Reset Switch

When fire alarm has issued, [Fire indicator], [Display zone] and [LCD screen] will all active. Press [Reset switch] after alarm status is clear and control panel will back to normal status. Butif detector has burnt or manual call point has not reset, the above reset process is invalid.

f. Voltmeter

indicates the operating voltage of control panel.

G. System Functions

a. Fan Activation Delay Function

To protect the designation of windpipe and gate from compressed deformation, user can choose to activate smoke evacuation gate first and delay the activation of fan. When activation has released, fan will be turned off first and evacuation gate will be closed after a delay.

b. Single System Transmission Function

When control panel is dual-system structure, user can use single system transmission to maintain normal

operation in case any error happened

c. Time Adjustment

Control panel has function of time recording, so the correct time could be adjusted from inside the control panel.

d. Indicator Power-Save Device

Control panel equipped with 2 sets of batteries for system & load standby power. When control panel is using battery power, power-save device will temporarily turn off the power of external indicator but it will blink once the module is activated.

e. Over-Current protection device

If short circuit or over-current happened during the operation of module, this device could isolate the feedback voltage on signal transmission wire between control panel and module.

## 6. Module Types :

The module series include control module 217B & 217T ; addressable detector base 118 ; output module 217A ; monitoring module 217K ; isolator 217H ; addressable manual call point 119.

## 7. Maintenance :

### A. Control Panel

#### a. Normal Status

[AC Indicator] should lights up, voltmeter should indicates 24V (permissible range 20~28V), all switches should in position, indicating lamps should light up.

#### b. Power-off status

Main power temporary off, [AC Indicator] lights off, [Battery indicator] lights up, voltmeter indicates 24V (permissible range 20~28V).

### B. General

#### a. Power Source

Check external switch, power capacity and stand-by power whether they are comply with safety requirements.

#### b. Control Panel

Check the self-tests whether they are normal.

#### c. Detector

Test the activation of detector whether it is normal, any defect on detector's confirmation lamp.

#### d. Manual Call Point

Check push botton & internal wiring whether they are normal.

#### e. Module

Check external wiring & transmission line whether they are disconnected or short circuit. Does transmission lamp flash normally ?

#### f. Insulation Test

It should over 250V 20MΩ between power terminal and earth terminal.

User should appoint professional institute or manufacturer to do a general inspection every year and related personnel or department should keep the record.

## 8. Simple Fault Elimination :

### Symptoms

AC power indicator OFF

Standby power failed

Fault indicator ON

Fire status can not be reset

Printer fail to work

Telephone does not work

Module keep sending disconnection signal to control panel, and module's disconnection indicator is ON

Control panel dose not received alarm signal when module is active.

Fire indicator dose not light ON

Alarm bell unable to sound

Fan unable to active

Evacuation gate unable to active

Buzzer unable to sound

Smoke detector false alarm

Heat detector false alarm

### Conclusions

Check AC power switch

Check AC power fuse

Check battery or DC power switch

Check DC power fuse

Test the battery for normalization

Check the contents displayed on LCD screen

Check detector or manual call point

No paper

No power

Check telephone wire for connection

Check wire connection between detector and base or module

Check wire connection between module and control panel

Check whether bulb is burnt, external wire is disconnected or fuse is burnt

Check the wire connection

Check the bell for normal operation

Check the module for bell contact

Check the module (no output)

Check the fan (no power)

Check the module for output

Check the gate for normal operation

Check the gate for main power

Check the module's buzzer contact

Check the buzzer for normal operation

Check the input power

Check the "B+" fuse on control panel

Check the detector for normal operation

Check the detector for dust pollution

Check the module for normal operation

Check the detector for normal operation

Big change on ambient temperature

High ambient humidity

Check the module for normal operation